

GAS NAME (ガス名)	O ₂ 、N ₂ 、Ar etc.
HYDROSTATIC TEST PRESSURE (耐圧試験圧力)	24.5 MPa
GAS-LEAKAGE TEST PRESSURE (気密試験圧力)	14.7 MPa
SAFETY DISC BURST PRESSURE (安全弁作動圧力)	16.7~19.6 MPa
FUSIBLE METAL (可溶合金)	100~110 °C

※ 附属品検査受検品

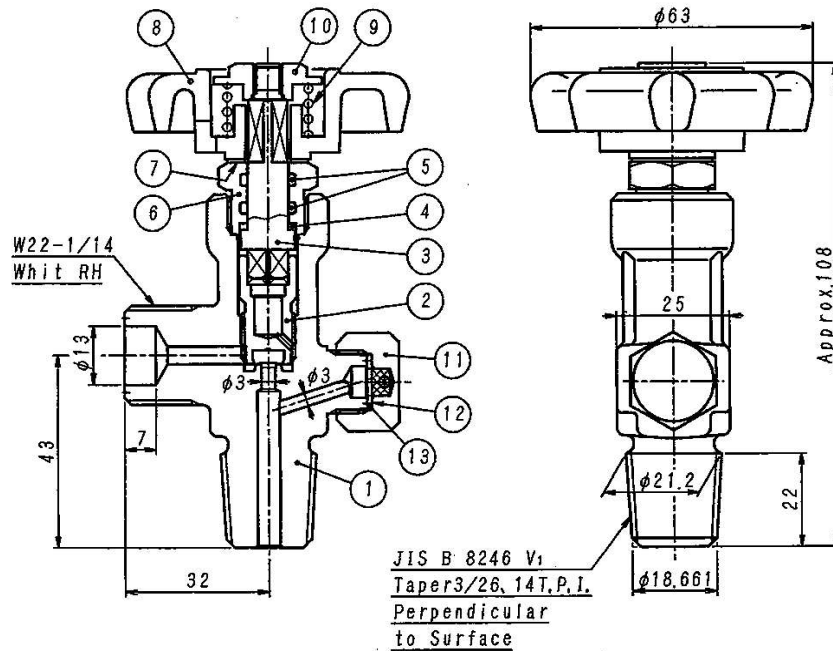
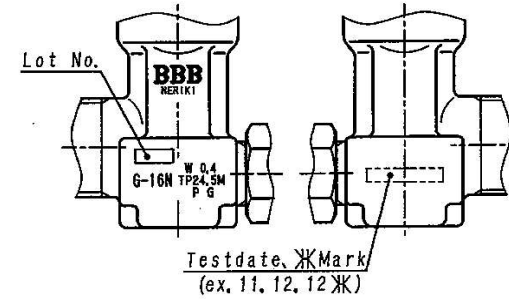

ITEM	PARTS No.	NAME OF PARTS	MATERIAL	No. REQ'D	REMARKS
13		Packing (パッキン)	Polyacetal, ポリアセチル Resins (樹脂)	1	
12		Safety Disc (安全板)	Copper, C1220	1	
11		Safety Cap (安全弁ナット)	Brass, C3771	1	W/Fusible Metal
10		Handwheel Nut (ナット)	*Zn Die-Casting, ZDC	1	
9		Spring (ハンドルバネ)	Stainless Steel, SUS304 -WPB	1	
8		Handwheel (ハンドル)	*Al Die-Casting, ADC	1	
7		Washer (ハンドル下パッキン)	Nylon (ナイロン)	1	
6		Gland Nut (グランドナット)	Brass, C3771	1	
5		O Ring (Oリング)	EPDM	2	
4		Packing (パッキン)	Polyacetal, ポリアセチル Resins (樹脂)	1	
3		Spindle (スピンドル)	Brass, C3771	1	
2		Seat Assembly (シートアセンブリ)	Brass, C6782	1	Disc: Nylon66
1		Body (本体)	Forged Brass, C3771	1	

CAREER ▲DEC.12.2011 (M.S) C.No.11-911	NAME G-16N TYPE VALVE	DWG. No. G-16N-051-1	REV. 1
SCALE 1/1	DATE DEC. 12. 2011	APPR. L. CHKD. DESIGN DRAWN	T. No. 3-