

改訂 Revision

改訂番号 Ecn. No	場所 Zone	改訂 Ver.	改訂内容 Description	日付 Date	承認 Approved

普通寸法公差		
範	圍	許容差
0をこえ	6以下	±0.1
6をこえ	18以下	±0.2
18をこえ	30以下	±0.3
30をこえ	60以下	±0.4
60をこえるもの		±0.5
変更欄		
記号	日付	

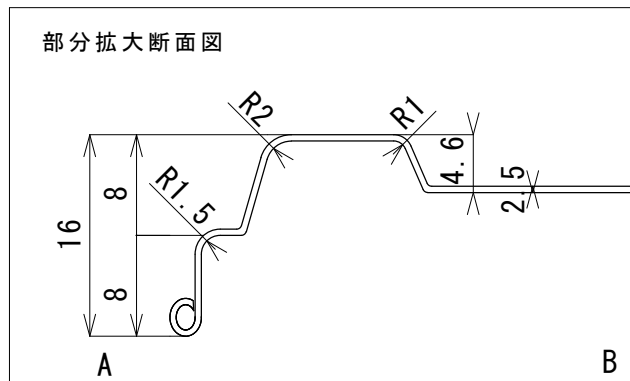
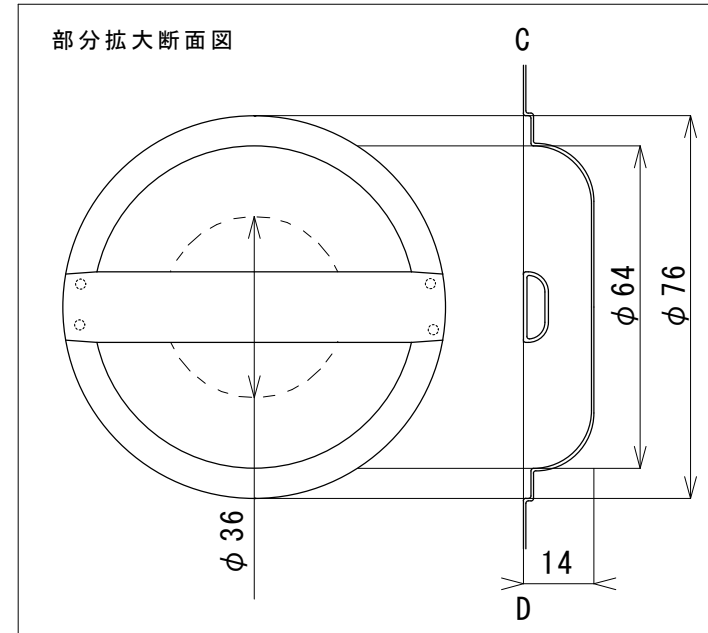
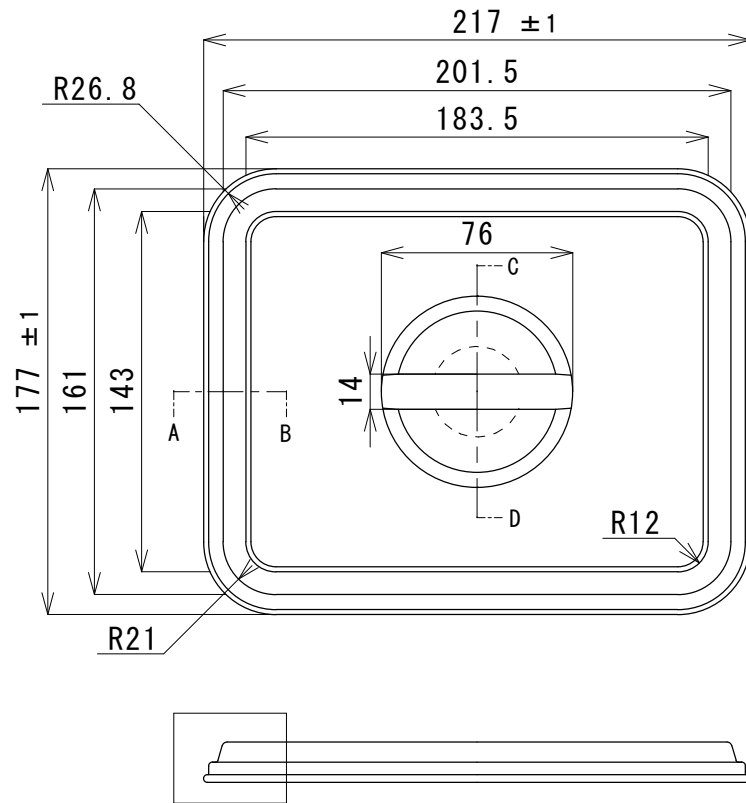

備考

\_\_\_\_\_

\_\_\_\_\_

\_\_\_\_\_

番号 Ref. No	構成部品番 Parts No.	構成部品名称 Name of Parts	個数 quantity	材料 Materials	摘要 Remarks
承認 approved	検図 checked	担当 designed	製品名 Product		
			角バット蓋キャビネット		
縮尺 Scale	1:3	第三角法 Third Angle Projection	材質 material	SUS304	品番 Pro. No
			板厚 thickness	t0.5	重量 weight
			製図 drawn by	堤 2016/09/08	図番 Dwn. No
					約195g