

### Description

The Wesco Knock Down Drum Truck is designed specifically for lifting 30 and 55 gallon poly drums. The truck is sent knocked down and boxed, requiring minimal assembly before operation. It features completely removable and interchangeable parts.

This product is distributed by:

**Wesco Industrial Products, Inc**  
1250 Welsh Road  
North Wales, PA 19454  
Tel: 215-699-7031 Fax: 215-699-3836

Contact the factory for parts information and ordering.  
Visit us on the web at [www.wescomfg.com](http://www.wescomfg.com)

### Unpacking

When unpacking the Wesco Product, check carefully for shipping damage and missing parts. If damage has occurred or any parts are missing, file a claim with the delivering carrier within 24 hours and notify the dealer from whom the unit was purchased.

### Warranty Repairs

If the unit does not work properly, contact your dealer or the factory (215-699-7031) for units less than 90 days old.

### Non-Warranty Service

If units are older than 90 days, repairs can be made easily on site with factory supplied parts.

**NOTE:** Do not send units to the factory for service without first obtaining a "Return Merchandise Authorization" (RMA) number from the customer service department. We will not be responsible for merchandise returned without proper authorization.

### Warning

- DO NOT move with drum unless truck's nose prongs are positioned evenly and fully under drum.
- Use extreme caution when moving over uneven floors.
- DO NOT use on stairs or inclines.
- Use only for handling 30 or 55 gallon poly drums.
- Periodically check for loose or worn hardware; If found

### LIMITED WARRANTY

WESCO INDUSTRIAL PRODUCTS (WESCO) warrants to the purchaser of this product for a period of ninety (90) days from the date of purchase that this product shall be free of defects in material and/or workmanship, as follows:

1. WESCO will supply, at no charge, new or rebuilt replacements for any part that fails through a defect in material and/or workmanship during the warranty period. To obtain warranty service, you must deliver the product prepaid, to the WESCO factory.

2. This warranty does not cover any product or product part which has been subject to accident, misuse, abuse or negligence. WESCO shall only be liable under this warranty if the product is used the manner intended by the manufacturer as specified in the written instructions furnished with this product.

REPAIR OR REPLACEMENT AS PROVIDED UNDER THIS WARRANTY IS THE EXCLUSIVE REMEDY OF THE PURCHASER. ANY EXPRESS WARRANTY NOT PROVIDED IN THIS WARRANTY DOCUMENT, AND ANY REMEDY FOR BREACH OF CONTRACT THAT, BUT FOR THIS PROVISION, MIGHT ARISE BY IMPLICATION OR OPERATION OF LAW, IS HEREBY EXCLUDED AND DISCLAIMED. UNDER NO CIRCUMSTANCES SHALL WESCO BE LIABLE TO PURCHASER OR ANY OTHER PERSON FOR ANY INCIDENTAL OR CONSEQUENTIAL DAMAGES, WHETHER ARISING OUT OF BREACH OF WARRANTY, EXPRESS OR IMPLIED, A BREACH OF CONTRACT OR OTHERWISE. EXCEPT TO THE EXTENT PROHIBITED BY APPLICABLE LAW, ANY IMPLIED WARRANTY OF MERCHANTABILITY AND FITNESS FOR ANY PARTICULAR PURPOSE ARE EXPRESSLY LIMITED IN DURATION TO THE DURATION OF THIS LIMITED WARRANTY.

Some states do not allow the exclusion or limitation of incidental or consequential damages, or allow limitations on how long any implied warranty lasts, so the above limitations may not apply to you. This warranty gives you specific legal rights, and you may also have other rights which vary from state to state.

### Replacement Parts

| Part No. | Description                                 |
|----------|---|
| 240215   | Handle                                      |
| 240212   | Belt Assembly                               |
| 240115   | Noseprong Set (40 & 45BT/BTW)               |
| 053730   | 10" Polyurethane Wheel <b>(240017 Only)</b> |
| 150691   | 10" Polyolefin Wheel <b>(240053 Only)</b>   |
| 109631   | Kickstand                                   |
| 050351   | Axle  |
| 108218   | Pin: Cotter 3/16 x 1-1/2"                   |
| 108208   | Washer: Flat 1" SAE                         |
| 240217   | Rear Rest                                   |
| 101145   | Pin: Clevis 3/8" Dia. X 2-1/4"              |
| 108282   | Bolt: Carriage 5/16-18 x 7/8"               |
| 109634   | Washer: Flat 3/8 SAE                        |
| 108876   | Screw: Hex Hd. Cap 5/16-18 x 2-1/2"         |
| 150268   | Nut: Keps 5/16-18                           |
| 108850   | Screw: Hex Head Cap 5/16-18 x 3"            |
| 101147   | Pin: Hair, Fits 1/4 to 1/2 Dia. X 1-3/8" L  |

### Optional Parts for Steel Conversion

| Part No. | Description                         |
|----------|-------------------------------------|
| 240210   | 3 <sup>rd</sup> Wheel Assembly      |
| 240214   | Hook Slide                          |
| 240060   | Noseprong Set w/ Hardware (20/15BT) |

### General Safety Information

**Warning: The Wesco Knock Down Drum Trucks are intended for specific functions. Please adhere to the following instructions to insure safe and proper use.**

- (1) Maximum capacity - 1000 Lbs.
- (2) Do not exceed rated capacity. Injury to persons or property may result from overloading and misuse.
- (3) **Only use on Poly Drums unless properly converted!**

### Operating Instructions

- (1) To properly operate the Knock Drum Truck DO NOT Pull Back Drum Until:
  - a. Either the chime hook securely engages drum rim or belt is securely tightened.
  - b. Both of truck's nose prongs are in full contact with bottom of drum.
- (2) Tilt drum with caution, maintaining control throughout.

# HARDWARE LIST (240017/53) PAGE 1

(Parts shown actual size)

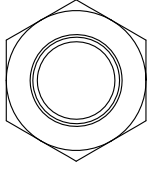
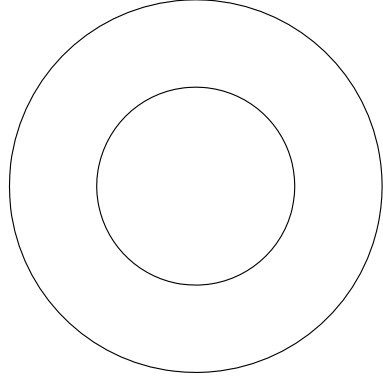
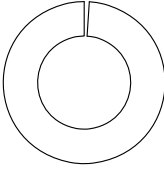
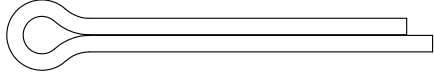
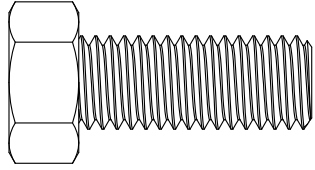
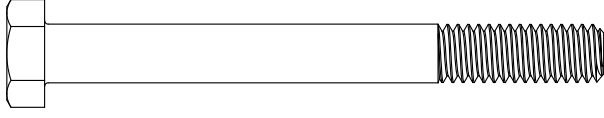
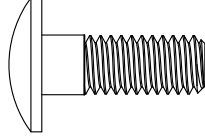
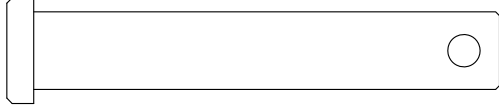
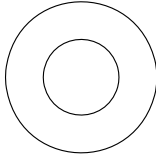
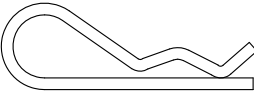
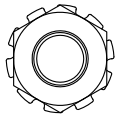
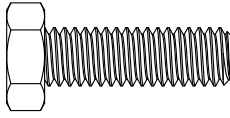
| CHECK/<br>QUANTITY | PICTURE/DESCRIPTION  | REF.<br># | CHECK/<br>QUANTITY | PICTURE/DESCRIPTION  | REF.<br># |
|--------------------|--|-----------|--------------------|--|-----------|
| ☐<br><br>(4)       | <br>NUT: HEX (PLTD) 1/2-13<br>[P/N: 100366]                 | <b>1</b>  | ☐<br><br>(4)       | <br>WASHER: FLAT (PLTD) 1" SAE<br>[P/N: 108208]                               | <b>7</b>  |
| ☐<br><br>(4)       | <br>WASHER: LOCK (PLTD) 1/2" MED<br>[P/N: 108228]           | <b>2</b>  | ☐<br><br>(2)       | <br>PIN: COTTER (PLTD) 3/16 X 1-1/2"<br>[P/N: 108218]                          | <b>8</b>  |
| ☐<br><br>(4)       | <br>SCR: HEX HD CAP(PLTD) 1/2-13x1-1/4"<br>[P/N: 150211]    | <b>3</b>  | ☐<br><br>(1)       | <br>SCREW: HEX HEAD CAP (PLTD) 5/16-18 X 3"<br>[P/N: 108850]                  | <b>9</b>  |
| ☐<br><br>(1)       | <br>BOLT: CARRIAGE (PLTD) 5/16-18 X 7/8"<br>[P/N: 108282] | <b>4</b>  | ☐<br><br>(2)       | <br>PIN: CLEVIS 3/8" DIAMETER X 2-1/4" ZINC PLATED<br>[P/N: 101145]          | <b>10</b> |
| ☐<br><br>(1)       | <br>WASHER: FLAT (PLTD) 3/8 SAE<br>[P/N: 109634]          | <b>5</b>  | ☐<br><br>(2)       | <br>PIN: HAIR, FITS 1/4 TO 1/2 DIAMETER X 1-3/8"<br>LENGTH<br>[P/N: 101147] | <b>11</b> |
| ☐<br><br>(4)       | <br>NUT: KEPS (PLTD) 5/16-18<br>[P/N: 150268]             | <b>6</b>  | ☐<br><br>(1)       | <br>SCR: HEX HD (PLTD) 5/16-18x1"<br>[P/N: 108149]                           | <b>12</b> |

# HARDWARE LIST (240017/53) PAGE 2

(Parts shown actual size)

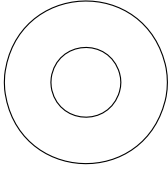
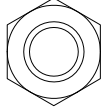
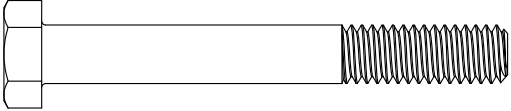
| CHECK/<br>QUANTITY                  | PICTURE/DESCRIPTION  | REF.<br># |
|-------------------------------------|--|-----------|
| <input type="checkbox"/><br><br>(1) | <br>WASHER: FLAT (PLATED) 5/16" USS<br>[P/N: 108878]                | <b>13</b> |
| <input type="checkbox"/><br><br>(1) | <br>NUT: LOCK, HEX (PLATED) 5/16-18 W/ NYLOCK<br>[P/N: 108132]      | <b>14</b> |
| <input type="checkbox"/><br><br>(2) | <br>SCREW: HEX HEAD CAP (PLATED) 5/16-18 X 2-1/2"<br>[P/N: 108876] | <b>15</b> |

## TOOLS REQUIRED:

- [1] Pliers
- [2] 1/2" Wrenches or Sockets + Ratchet
- [2] 3/4" Wrenches or Sockets + Ratchet

## RECOMMENDED OPTIONAL PARTS

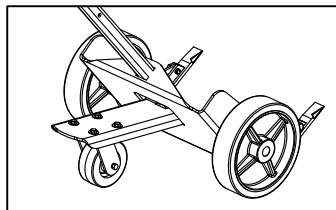

### 3rd WHEEL

- Ergonomic design, better maneuverability
- Better load support
- Helps reduce breakover effort
- Assembles without tools
- 5" x 2" swivel caster
- Two models: #240210 for steel trucks, 13 lbs.  
#240211 for 304 stainless trucks, 14 lbs.

### STEP 1

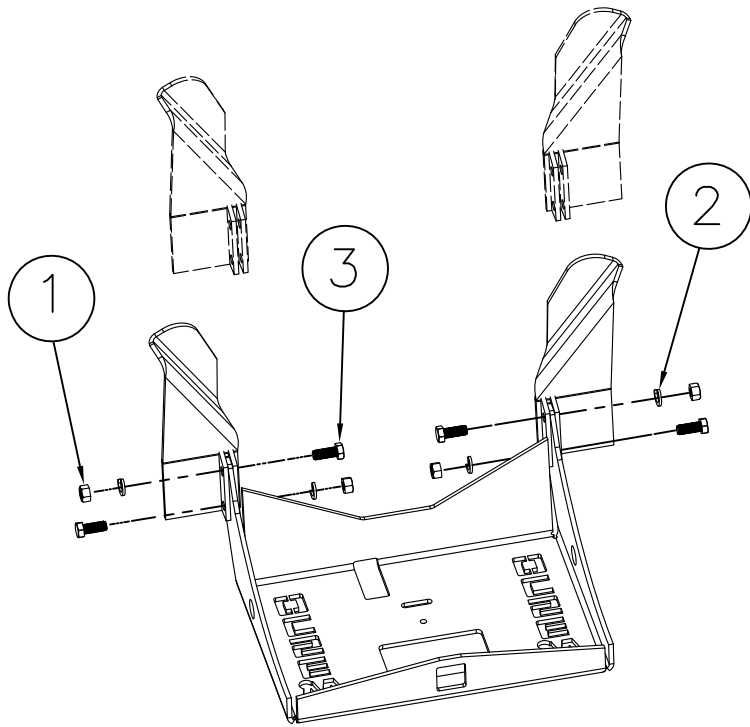

Fasten right and left toes to base using four nuts(1), four lockwashers(2), and four bolts(3). Tighten securely.

### STEP 2

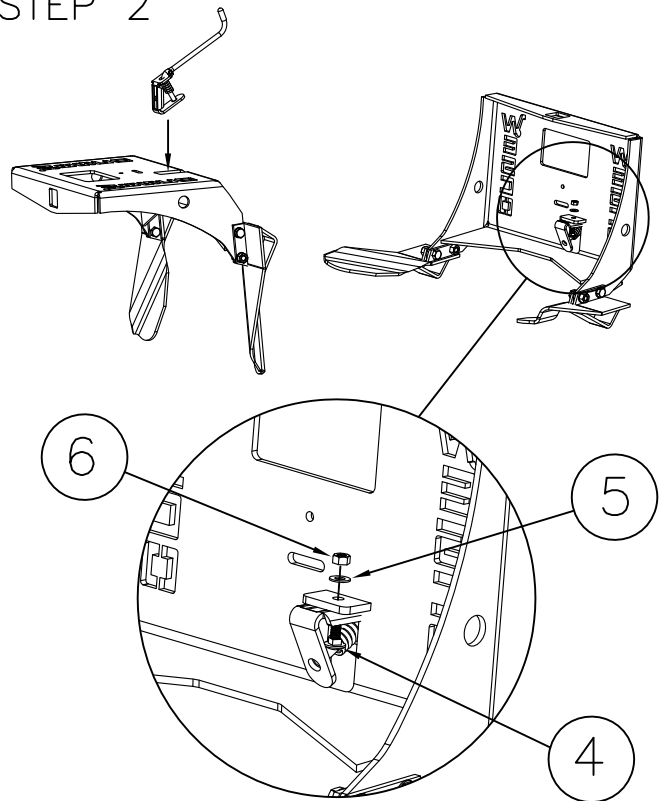

Insert kickstand through rear of base and secure using one bolt(4), one washer(5), and one nut(6).

### STEP 3

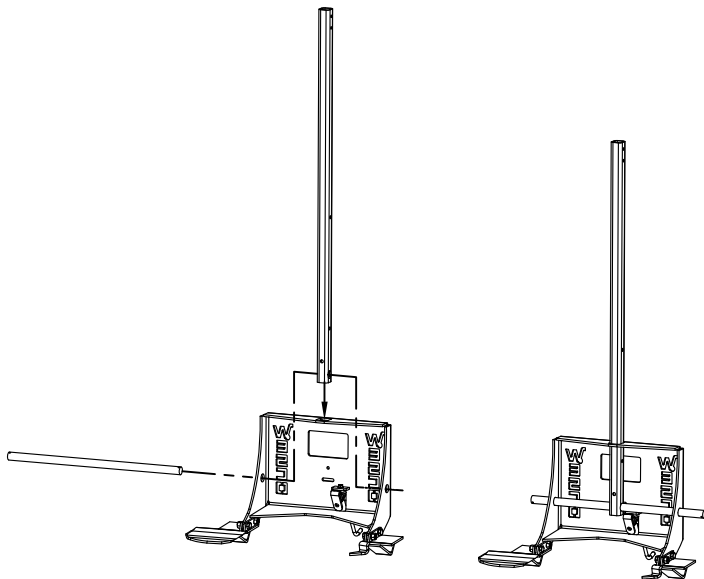

Insert axle through one axle hole in base, through post, and through opposite base axle hole.

### STEP 4

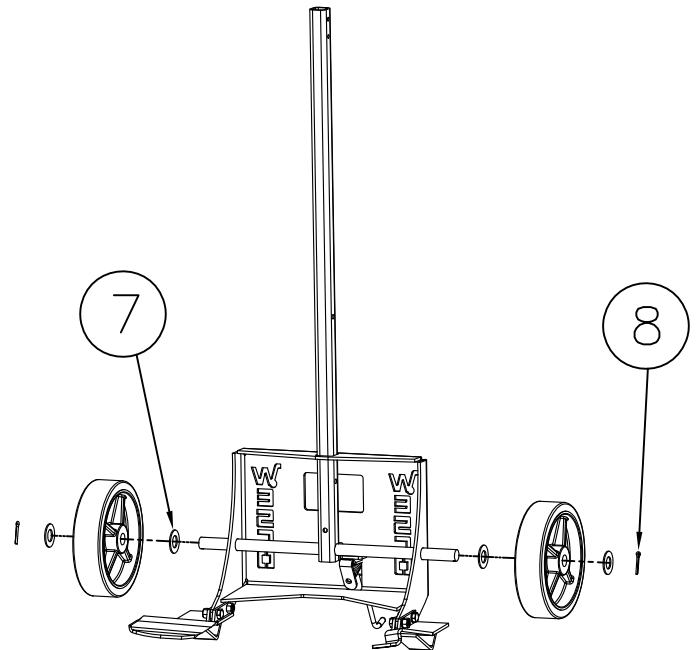

Secure wheels using four washers(7) and two cotter pins(8).

# STEP 5

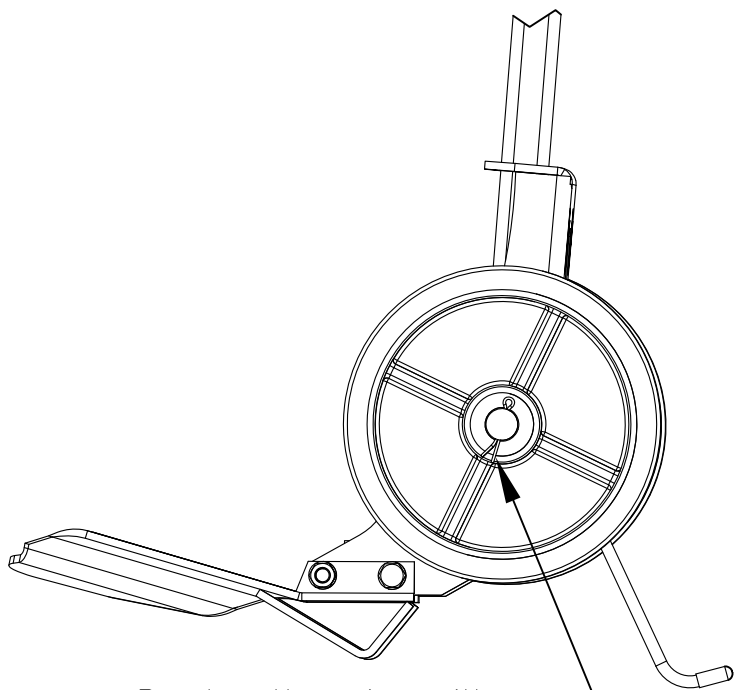

Bend cotter pins with pliers to secure wheel assembly.

# STEP 6

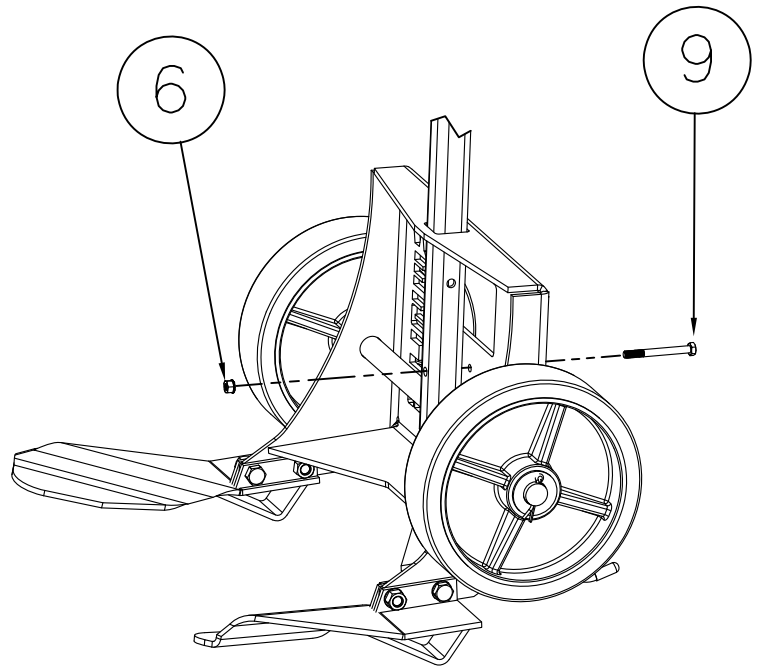

Lock post to base using one nut(6) and one bolt(9).

# STEP 7

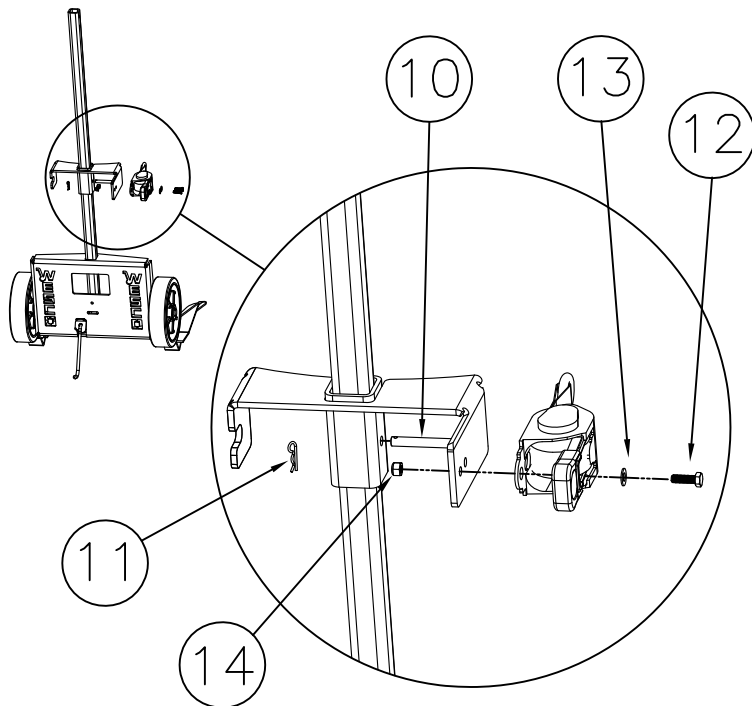

Slide belt holder down post and secure with one clevis pin(10) and one hairpin cotter(11). Mount belt assembly to belt holder using one bolt(12), one washer(13), and one locknut(14).

# STEP 8

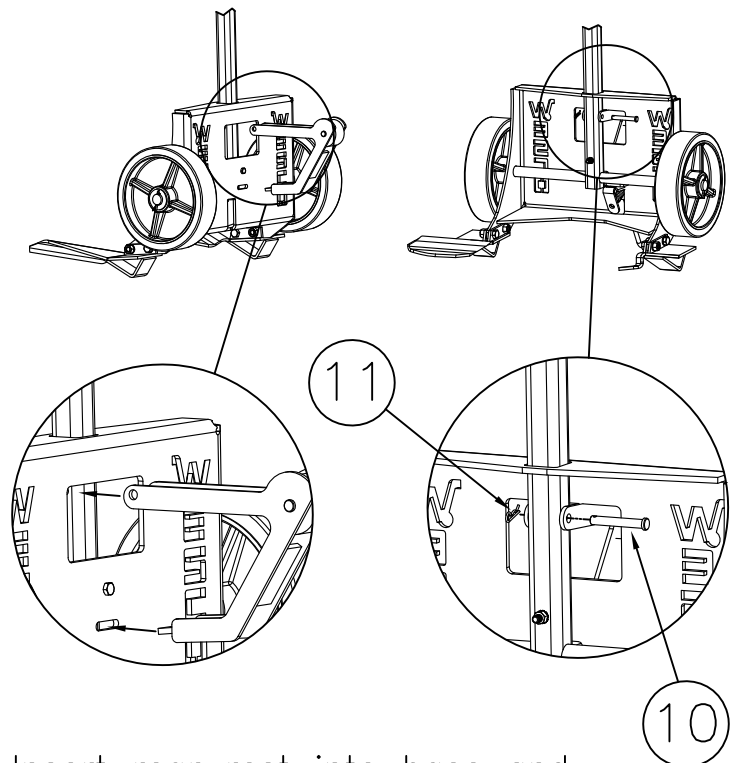

Insert rear rest into base and secure with clevis pin(10) and hairpin cotter(11). Ensure tab of rear rest is fully seated in base.

# STEP 9

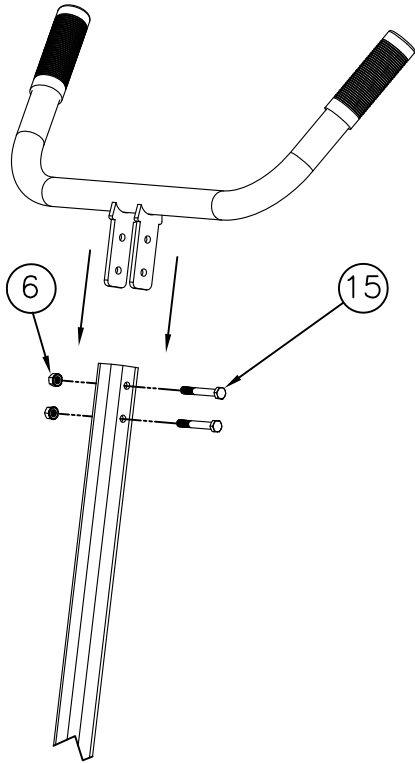

Slide handle onto post and fasten with two locknuts(6) and two bolts(15).

# COMPLETED TRUCK

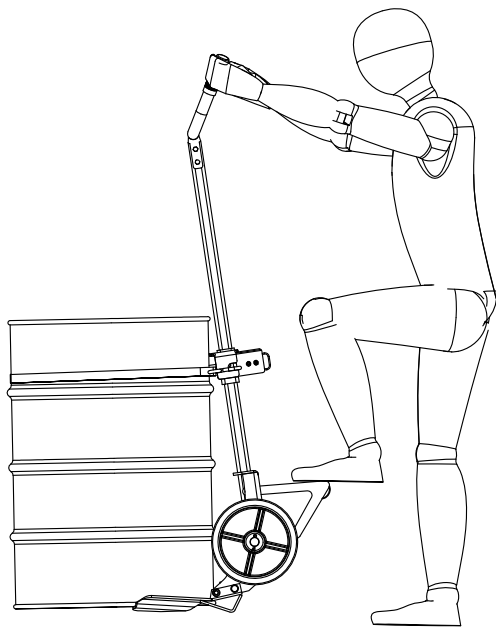
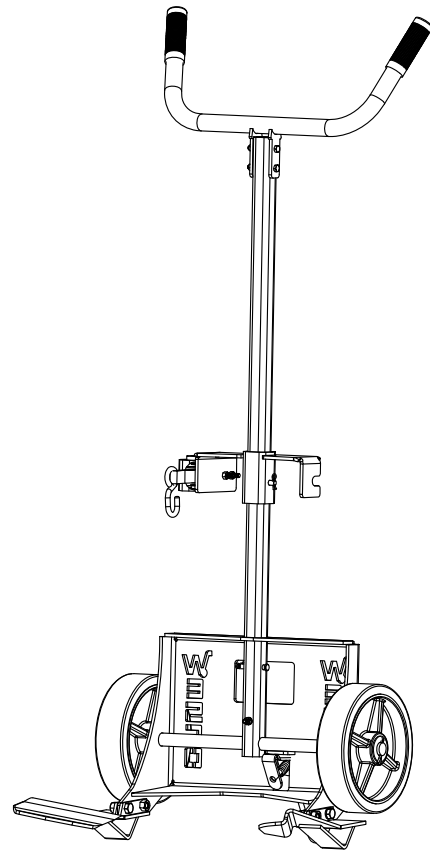

## BREAKOVER POSITION

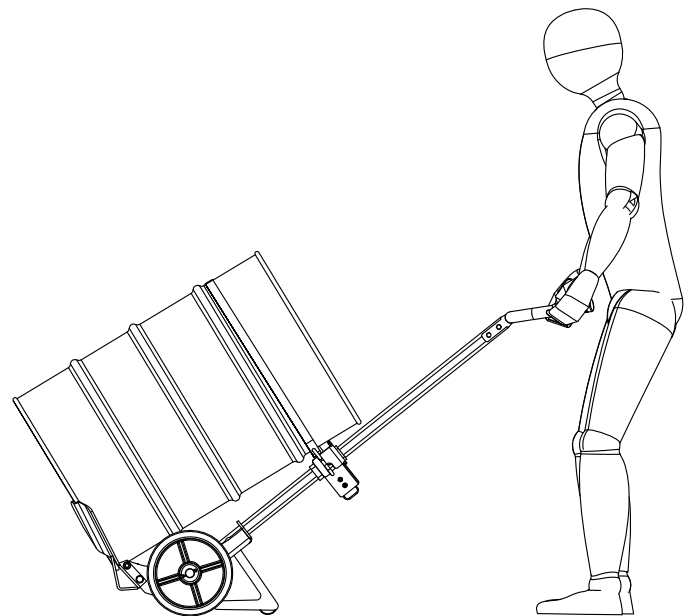

## REST POSITION