

Universal Vices Super Precision

UV-SP

Versatile machine vices with all degrees of freedom allows the work piece to be set at any desired angle

Low height construction makes these useful on complicated grinding jobs

One fixed horizontal axis which allows the work piece to be rotated at any angle

Fully graduated 360° swivel base for complete rotation on the vertical axis

Third angular slide with moving axis allows for any setting in the 3D plane

Manufactured from close grained hi-tensile seasoned cast iron with fully hardened and ground tool steel jaws

Ergonomically designed all steel handle assembled on the spindle crank with a spring loaded mechanism providing positive grip

Fasteners provides strength and rigidity

Milled slot in base allows for accurate location on the machine table using rectangular locating nuts

"Hold Down" slots allow for secure clamping of the vice on the work table

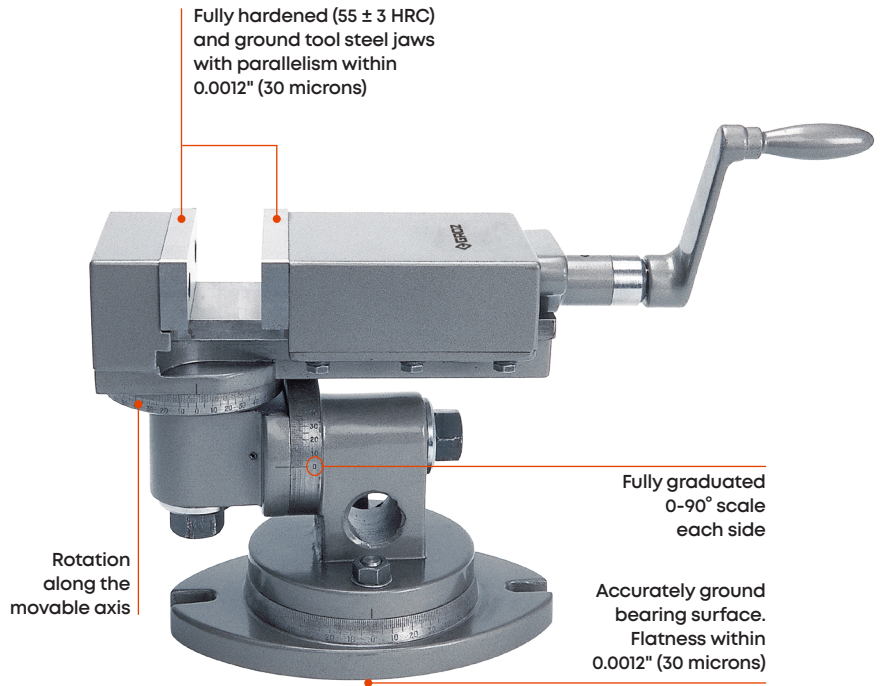

Rotation along the movable axis parallel to the axis of the swivel base



Rotation along the axis perpendicular to the axis of the swivel base



A combination of settings along the 3 axes produces the desired compound angle



A typical case of the Universal vice set perpendicular to the base by rotation along the movable scale

ORDERING INFORMATION

CAT NR.	ORD NR.	JAW WIDTH		JAW OPENING		JAW DEPTH		NET WEIGHT (KG)	BOX QTY.
		(INCH)	(MM)	(INCH)	(MM)	(INCH)	(MM)		
UV/SP/50	35030	2	50	2	50	7/8	22.6	3.5	6
UV/SP/100	35031	4	100	4	80	1-1/4	32	13.4	1