

PALMGREN

1-TON ARBOR PRESS WITH DEPTH STOP COLLAR

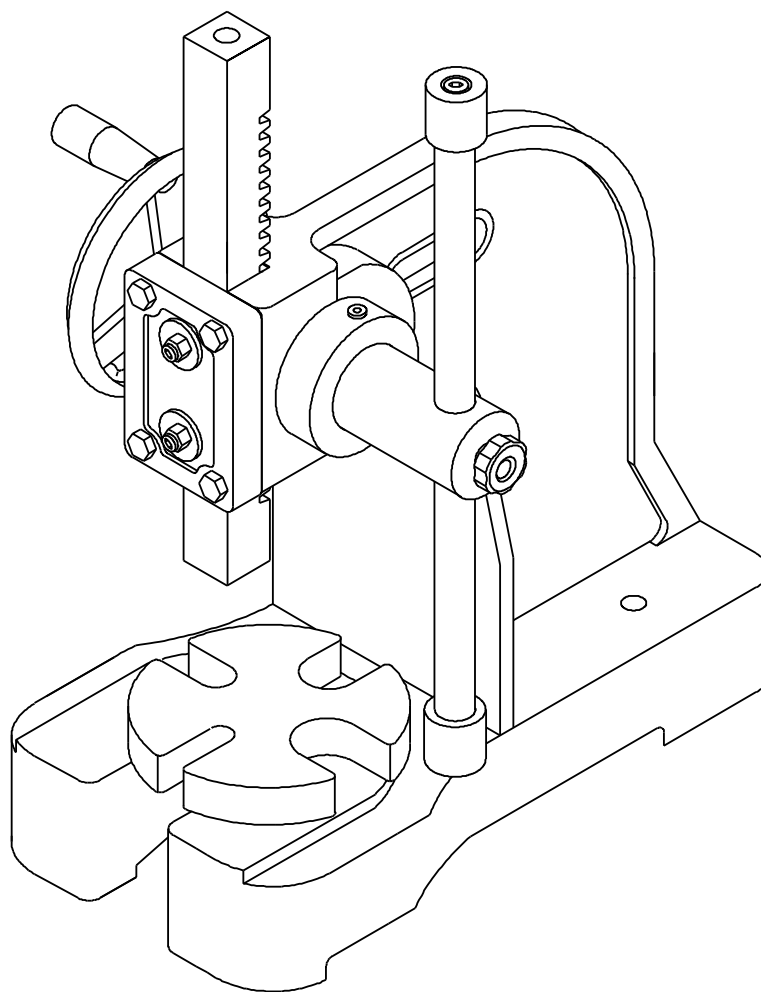

Read carefully and follow all safety rules and operating instructions before first use of this product.

DESCRIPTION

Palmgren Arbor Press is designed for riveting, squeezing, bending, punching, flattening, removing a bearing or pressing in bearings. Removable, rotating, machined anvil has 4-slots to provide convenient support for workpieces that vary in size and shape. Arbor press comes with three punches and a magnetic insert to hold the punch. Press is equipped with handwheel to perform light presswork. Press is suited for work in production lines as well as in machine shops, automotive repair shops and home workshops.

SAFETY RULES

- For best operation, the arbor press must be bolted to a stationary object that is also affixed to the floor.
- When using the press, be sure the work is mounted securely in it. Do not attempt to use the press with the workpiece mounted on an angle.
- Use only accessories designed for the arbor press. Attachments and equipment used in the pressing operation must be as strong as the press. Use steel collars and blocks to press against the workpiece.
- Do not overload the press by using handle extensions (cheater bars).
- Remove arm-handle from arbor press before using handwheel.
- When not in use, the ram should be in the down position to prevent accidents.
- Know the arbor press and accessories. Read and understand owner's manual.
- Wear a face shield or safety glasses.
- Never place hands in jeopardy.
- Always check your set up, i.e., see that the ram contacts workpiece squarely before applying pressure.
- Keep your mind on your work. Be alert.
- Make sure workpiece, punch, anvil and accessories are securely clamped.
- Don't force the arbor press or its accessories.

DIMENSIONS

Refer to Figure 1.

Model Type	61101C	
Base Length	L	10 ³ / ₄ "
Base Width	W	6 ⁵ / ₁₆ "
Height	H	11 ¹ / ₈ "
Max. Work Height	A	6 ¹ / ₈ "
Swing	2B	8"
Anvil Diameter	D	4 ¹ / ₂ "
Ram Dimension	R x R	1 x 1"

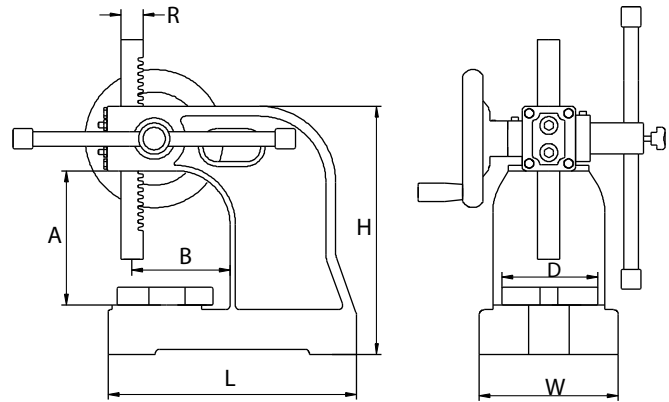

Figure 1 - Dimensions

OPERATION

Refer to Figure 2.

- Mount arbor press to bench or stand. Secure arbor press using two mounting holes on the body (Ref. No. 1). (Hardware is not supplied.)
 - To use with a punch remove set screw, handwheel and key (Ref. Nos. 18, 17 and 8) from pinion (Ref. No. 3). Remove pinion from the body. Remove ram (Ref. No. 2), mount ram upside down so the punch hole is facing down. Replace pinion, key, handwheel and set screw. Insert the punch (Ref. No. 20) best suited to the job. Make sure that magnetic insert (Ref. No. 15) is holding the punch.
 - To adjust the ram action to your requirements, use set screws (Ref. No. 13). All set screws should be tightened with the same amount of pressure. Secure set screws by tightening nuts (Ref. No. 12).
- WARNING:** Do not use handwheel before removing arm-handle from the arbor press. Failure to remove arm-handle may result in injury to operator or others.
- To use handwheel for light presswork, remove bolt (Ref. No. 4), cap (Ref. No. 5) and arm-handle (Ref. No. 7) from pinion.

DEPTH STOP COLLAR INSTALLATION:

The Depth Stop Collar allows to precisely adjust and/or limit the Arbor Press Ram Stroke. To install the Depth Stop Collar:

- Position the Collar over the Ram such that the two set screws is on the front side of the arbor press.



- Loosen the two set screws slightly with a wrench (not supplied) and slide the Collar over the Ram. Position the Collar at the desired height and tighten both the set screws

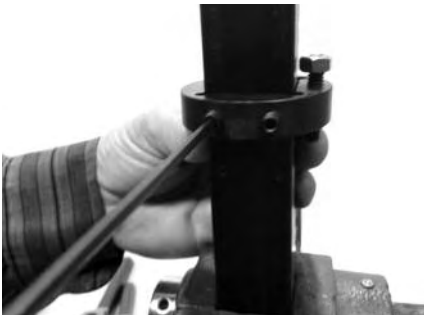

- For precise depth stop adjustment, turn the screw on the hex nut to the desired height. Secure the position of the screw by tightening the hex nut until it bottoms out on the arbor press frame.



MAINTENANCE

- Oil the pinion periodically through the oil fitting, and grease the ram rack whenever necessary. Keep work area clean. Clean the arbor press of dirt and debris after every use.
- If the ram is loose and drops by itself, tighten screws (Ref. No. 13) for adjustment. All screws should be tightened with the same amount of pressure.

WARRANTY

Palmgren warrants their products to be free of deficiency in material or workmanship. The duration of this warranty is expressly limited to one year parts and labor unless otherwise noted beginning from the date of delivery to the original user. The following Palmgren products carry the following warranties on parts with a 1 year warranty on labor:

- | | |
|--------------------------------------|--------------------------------|
| • USA Machine vises – Lifetime | • Tapping machines – 2 years |
| • Imported Machine vises – 2 years | • Drilling machines – 2 years |
| • Bench vises – 2 years | • Finishing machines – 2 years |
| • Positioning tables – 2 years | • Band saws – 2 years |
| • Bench grinders & buffers – 3 years | • Work stands – 2 years |

The obligation of Palmgren is limited solely to the repair or replacement, at our option, at its factory or authorized repair agent of any part that should prove deficient. The warranty does not cover expendable and/or wear parts (i.e. v-belts, coated abrasives), damage to tools arising from alteration, abuse or use other than their intended purpose, packing and freight. Purchaser must lubricate and maintain the product under normal operating conditions at all times. Proper use and care instructions are provided in the operator's manual. Failure to follow these instructions will void the warranty.

This warranty is the purchaser's exclusive remedy against Palmgren for any deficiency in its products. Under no circumstances is Palmgren liable for any direct, indirect, incidental, special or consequential damages including lost profits in any way related to the use or inability to use our products. This warranty gives you specific legal rights which may vary from state to state.

SERVICE & REPAIR

1. If a Palmgren product requires a repair or warranty service **DO NOT** return the product to the place of purchase.
2. All warranty related work must be evaluated and approved by Palmgren.
3. Prior to returning any item the user must obtain factory approval and a valid RGA number.
4. For instructions and RGA number call toll free (800) 621-6145.

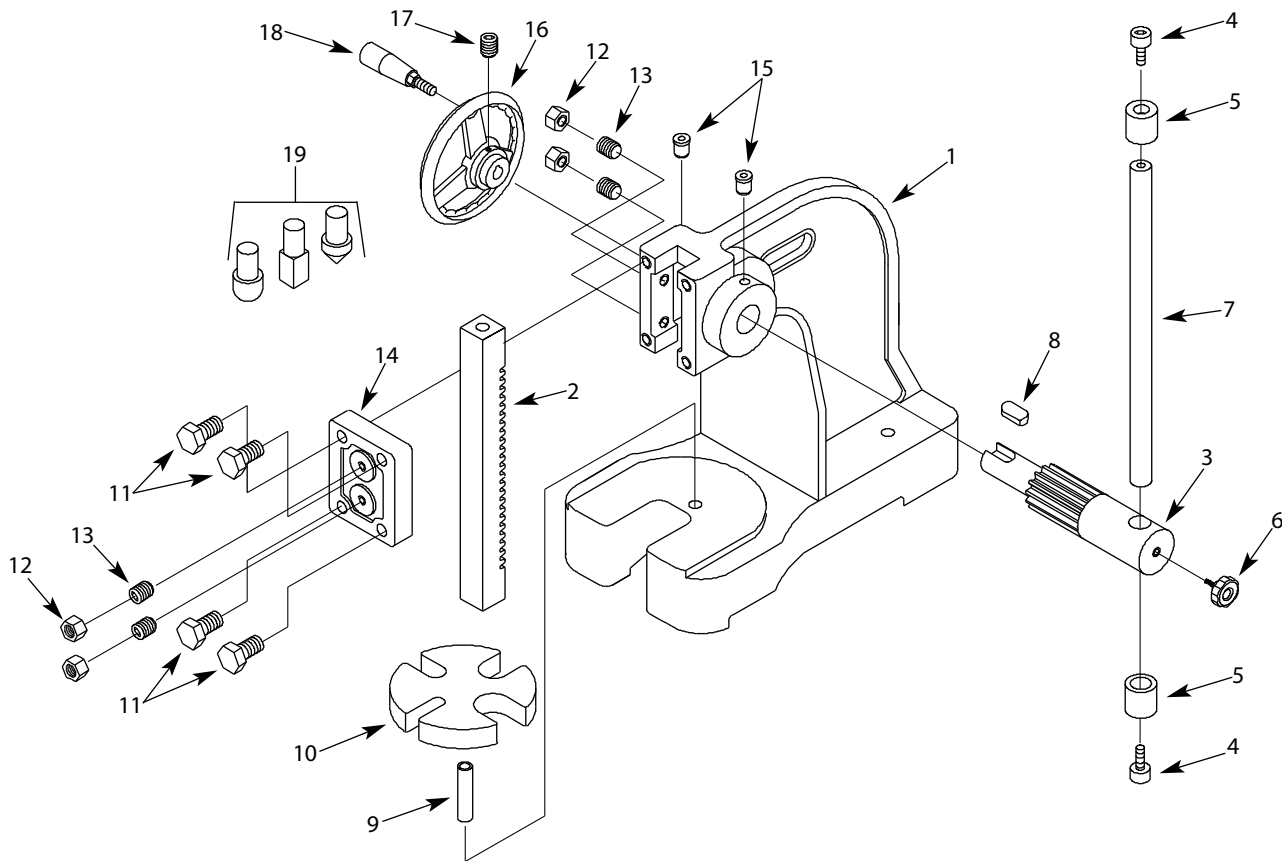

Figure 2 - Replacement Parts Illustration for 1-Ton Arbor Press

REPLACEMENT PARTS LIST FOR ARBOR PRESS

Ref. No.	Description	Part Number for: 61101C	Qty.
1	Body	†	1
2	Ram with Magnet	28803.00	1
3	Pinion	28804.00	1
4	6-1.0 x 25mm Socket Head Bolt	*	2
5	Cap	28805.00	2
6	Knob	28806.00	1
7	Arm-handle	28807.00	1
8	6 x 6 x 16mm Key	17330.00	1
9	Table Pin	01596.00	1
10	Anvil	28808.00	1
11	6-1.0 x 25mm Hex Head Bolt	*	4
12	6-1.0mm Hex Nut	*	4
13	6-1.0 x 20mm Set Screw	*	4
14	Face Plate	28809.00	1
15	Oil Fitting	17335.00	2
16	Handwheel	28810.00	1
17	8-1.25 x 8mm Set Screw	*	1
18	Handle	28811.00	1
19	Punch Set (3 pieces-round; point; square)	28722.00	1
Δ	Depth Stop Collar Assembly	35409.00	1
Δ	Operator's Manual	37082.00	1

Δ Not Shown.

* Standard hardware item available locally.

† Not available as replacement part.