

寸法図

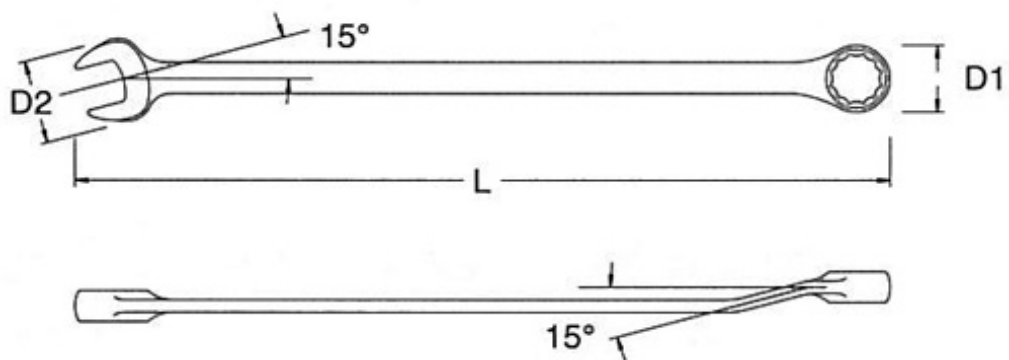

構成品

サイズ	L(全長)	D1	D2	重量(g)
1/4"	126	10.7	13.5	17
5/16"	139	13.9	16.7	28
3/8"	151	15.3	20.9	40
7/16"	166	17.7	23.0	50
1/2"	178	20.1	27.2	58
9/16"	191	21.5	29.3	78
5/8"	209	24.5	33.4	125
11/16"	226	26.7	35.5	133
3/4"	248	28.5	39.7	185
13/16"	270	30.6	43.9	212
7/8"	293	32.3	46.0	277

単位(mm)