

Floor Marking Tape Tool

Part No.	Part Name	QTY
04	Roller Assembly	1
36	Handle Assembly	1
52	Tape Holder Rack Assembly	1
63	Tape Holder Assembly	1

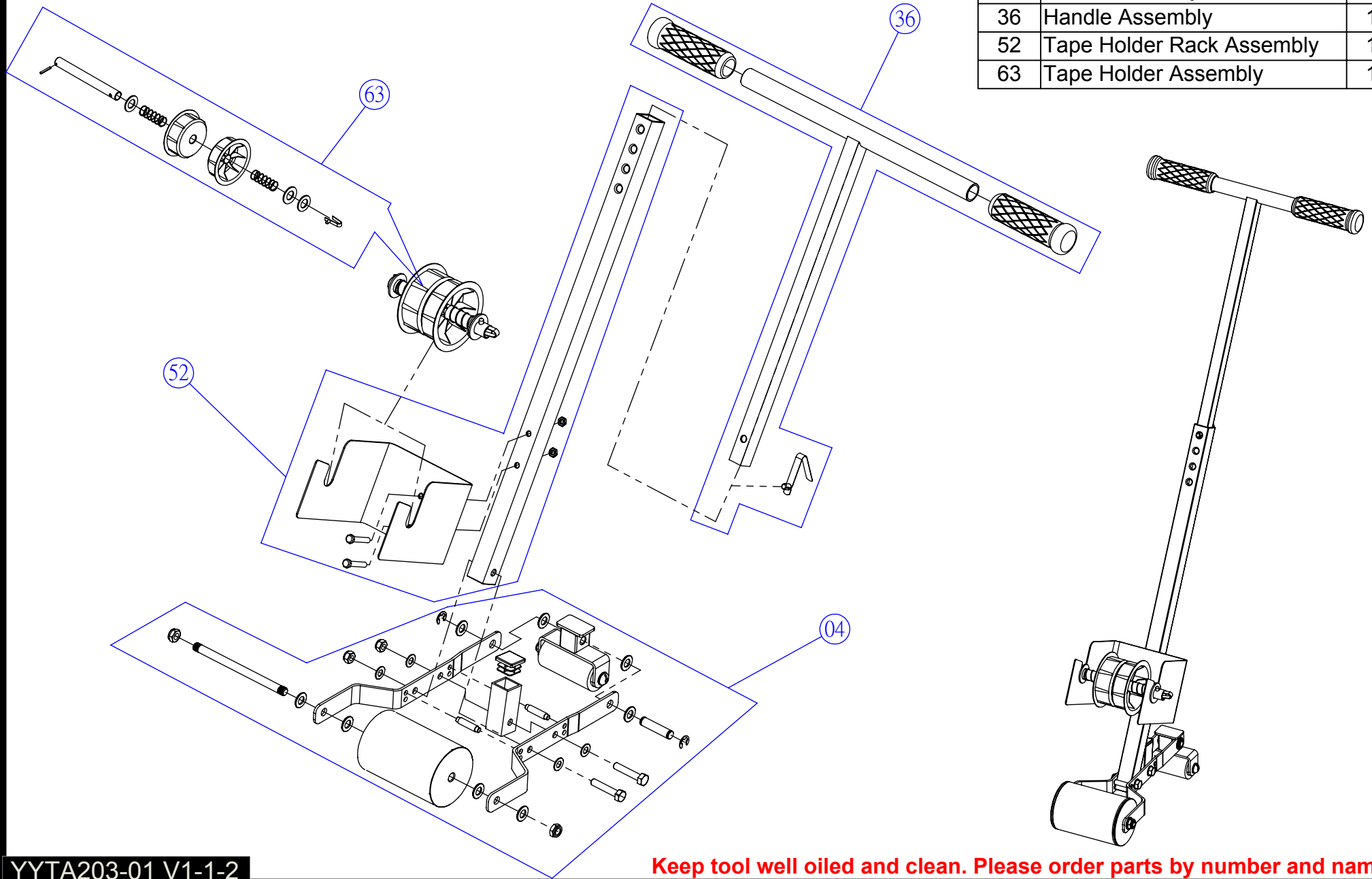

YYTA203-01 V1-1-2

Keep tool well oiled and clean. Please order parts by number and name.

Floor Marking Tape Tool

ASSEMBLING INSTRUCTIONS

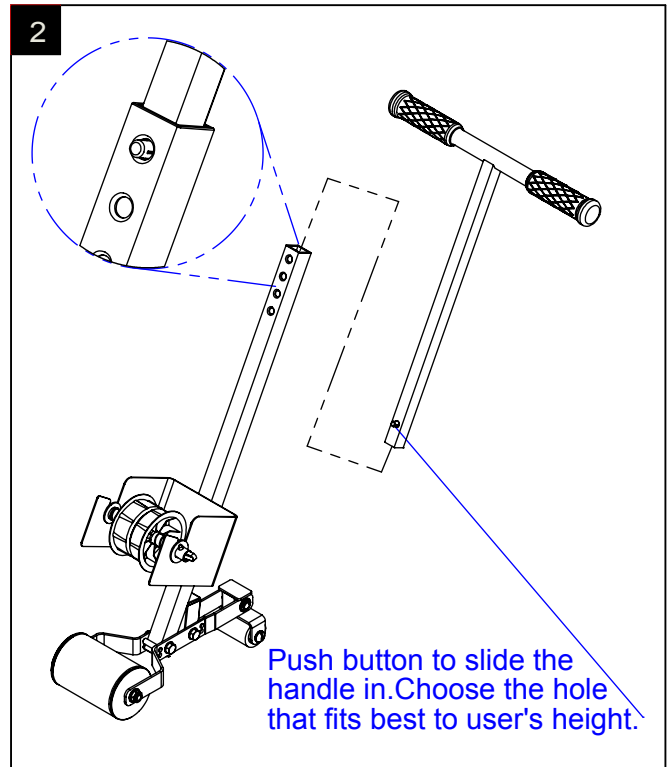
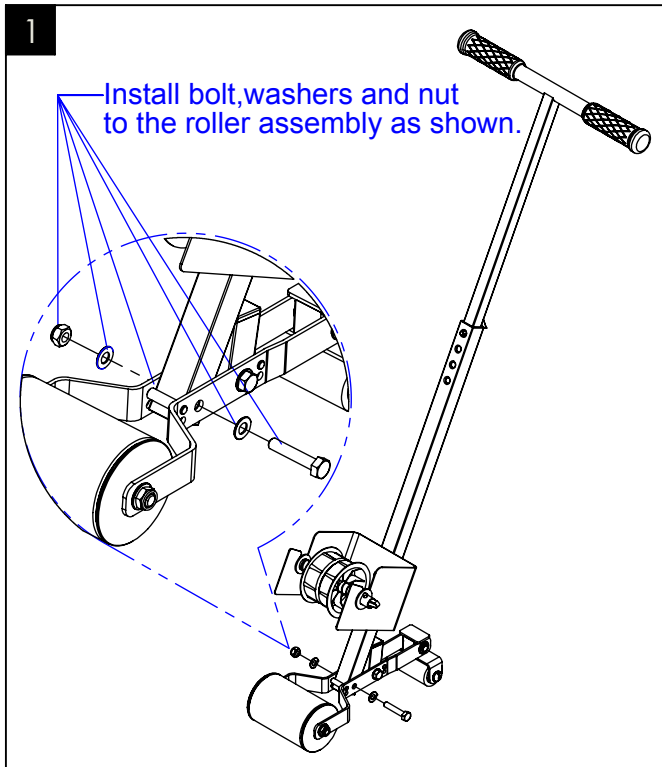

OPERATING INSTRUCTIONS

