

## Parts List

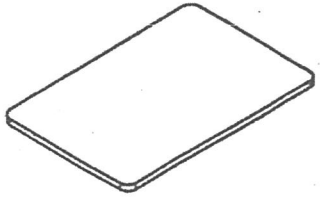

1. Wood top = 1

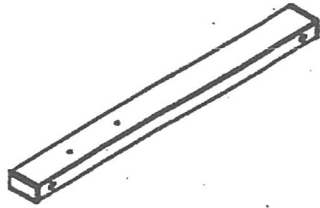

2. Right leg = 1

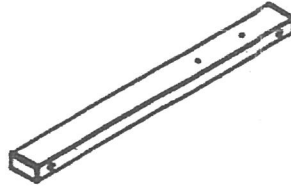

3. Left leg = 1

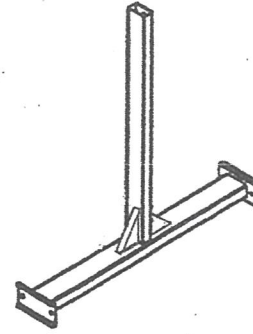

4. Base = 1

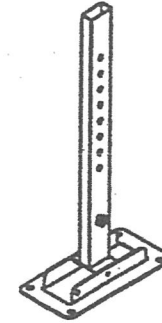

5. Upper support = 1

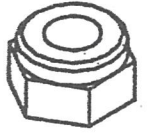

6. Locking nut = 1

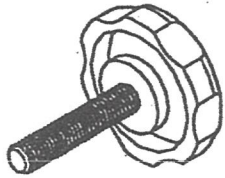

7. Tension knob = 1

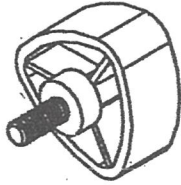

8. Tilt guide knob = 1



9. Tilt guide = 1

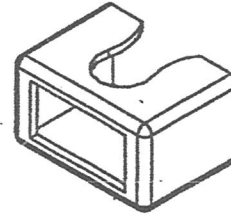

10. Plastic collar = 1



11. Paper guard = 1



12. Washer = 1

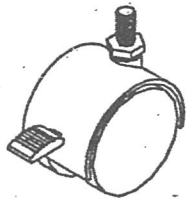

13. Caster w/brake = 2

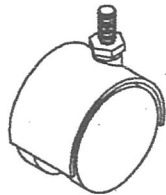

14. Caster w/o brake = 2

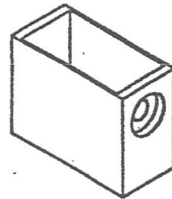

15. Inner plastic collar = 1

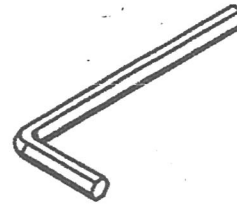

16. Allen wrench = 1



17. 1/2" bolt = 12



18. Washer = 1  
(large size)

**Instruction Sheet  
Model LX9128**



Customer Service Dept  
2245 Delany Rd  
Waukegan, IL 60087  
Ph: 847/244-1800 • 800/323-4656  
Fax: 847/244-1818 • 800/327-1698

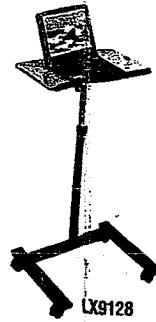

**Parts List**

Wood top = 1  
Right leg = 1  
Left leg = 1  
Base = 1  
Upper support = 1  
Tension knob = 1  
Tilt guide knob = 1  
Tilt guide = 1  
Plastic collar = 1

Paper guard = 1  
Caster w/brake = 2  
Caster w/o brake = 2  
Inner plastic collar = 1  
Allen wrench = 1  
1/2" bolt = 12  
Locking nut = 1  
Washer = 1  
Washer = 1 (larger size)

**Step 1**

Identify parts.  
Attach the tilt guide to the upper support using 1/2" bolt one washer, and one locking nut.

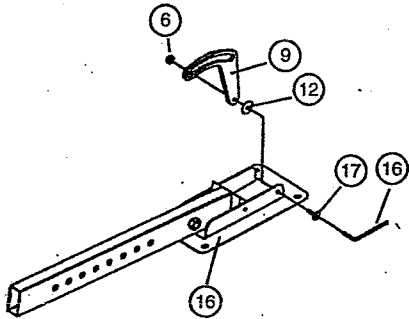

**Step 2**

Insert the shorter threaded knob and one washer through the tilt guide and into the threaded hole on the upper support.

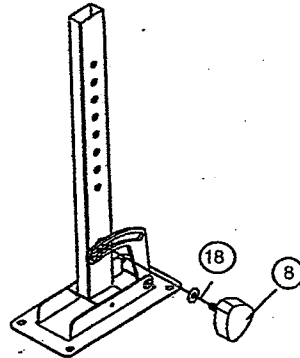

**Step 3**

Align the four holes on the upper support to the four holes on the top and bolt down with 1/2" bolts. Attach paper guard to the two threaded holes on the wood top using two 1/2" bolts.

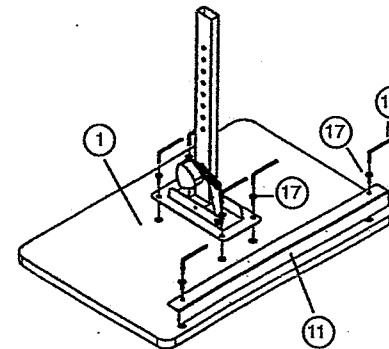

**Step 4**

Slide the locking collar and the inner plastic collar onto the upper support.

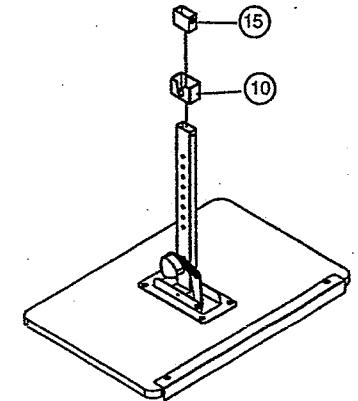

**Step 5**

Align the inner plastic collar to the hole on the bottom of the upper support and attach with 1/2" bolt.

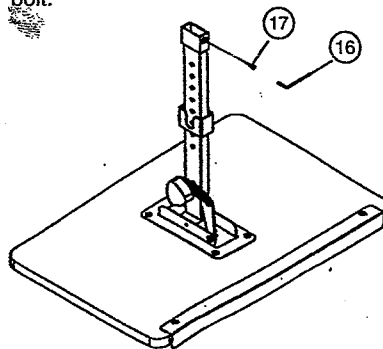

**Step 6**

Install casters to the right and left legs. Casters w/brake go opposite of the two holes on the side of the legs.

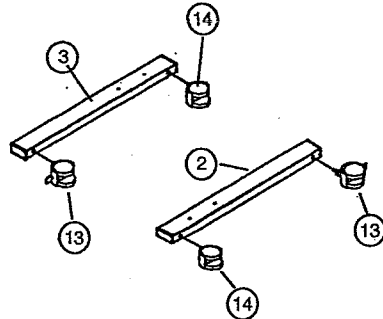

**Step 7**

Align the two holes on the left and right legs to the two holes on the leg supports on the base. Bolt down using 4 - 1/2" bolts.

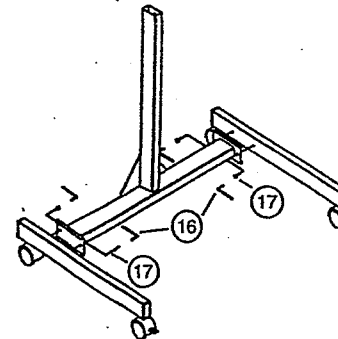

**Step 8/9**

Slide assembled top half onto the base. Align hole on the upper support to the threaded hole on the base to desired height and tighten down with the tension knob.

