

EA986GQ-150



EAN: 4047526611989

ID: 611988

Light duty swivel castor with top plate fitting, Wheel with thermoplastic rubber tread, with polypropylene wheel centre

Bracket:

Made of pressed steel, with double ball bearing in the swivel head, ball protection by the special top plate and ball disc design. The special Blickle dynamic riveting process of the swivel head results in minimal swivel head play and smooth rolling characteristics with an increased service life achieved by the work hardening of the ball race grooves. Bolted wheel axle. Zinc-plated, blue-passivated, Cr6-free.

Wheels:

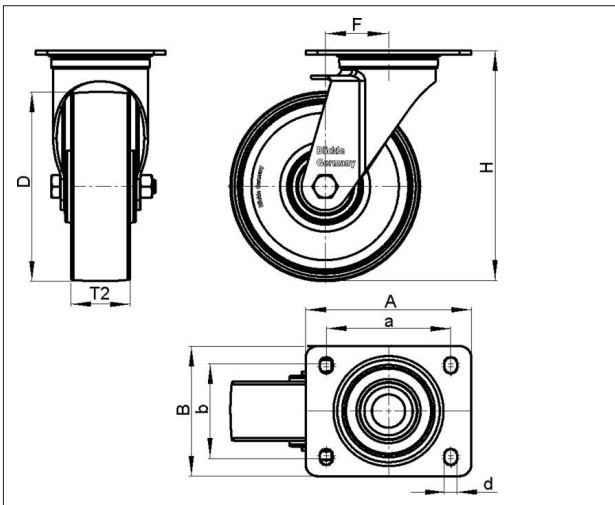

Tyre & running tread: Made of high-quality thermoplastic rubber elastomer (TPE), high operational comfort, low-noise operation, low rolling and swivelling resistance, good floor preservation, chemically bonded for an inseparable connection to the wheel centre. Tread colour: grey

Rim / wheel centre: Made of high-quality, impact-resistant polypropylene. Chemically bonded.



Technical data

Wheel Ø (D)	150 mm
Wheel width (T2)	32 mm
Load capacity	110 kg
Total height (H)	185 mm
Offset swvl castor (F)	40 mm
Unit weight	0.958 kg
Temperature range from	-20 °C
Temperature range to	60 °C
Tread & tyre hardness	85° Shore A
Bearing type	
Plate size (A,B)	90 x 66 mm
Bolt hole Ø (d)	8,5 mm
Bolt hole spacing (a,b)	75x45/61x51 mm

Rolling resistance	
Operating noise	
Floor surface preservation	