

EA986HH-2



EAN: 4047526277987

ID: 277988

, Wheel with pneumatic tyres, with pressed steel rim

Bracket:

Made of heavy pressed steel, with double ball bearing in the swivel head, strong central kingpin, swivel head seals. The special Blickle dynamic riveting process of the swivel head results in minimal swivel head play and smooth rolling characteristics with an increased service life achieved by the work hardening of the ball race grooves. Bolted wheel axle. Zinc-plated, blue-passivated, Cr6-free.

Wheels:

Tyre & running tread: Pneumatic tyre with tube, outstandingly high operational comfort, exceptionally high floor preservation, PAH conform acc. to EU directive 2005/69/EC. Tread colour: black

Rim / wheel centre: Made of pressed steel, with tubular steel hub, zinc-plated, blue-passivated, Cr6-free. Tyre mounted on rim.

Variants:

mit Feststeller "stop-top"

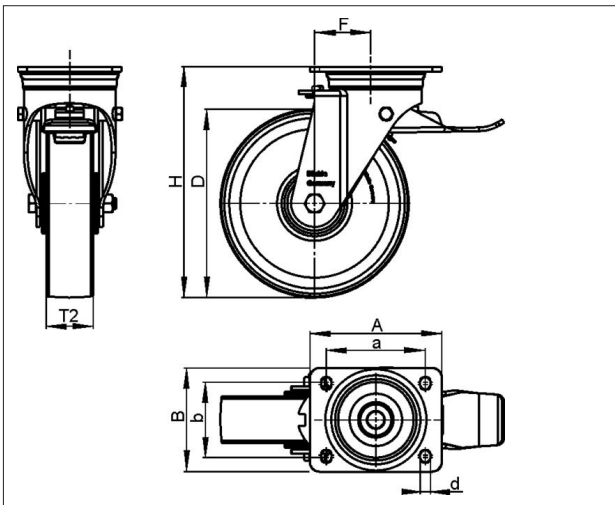

Technical data

Wheel Ø (D)	220 mm
Wheel width (T2)	65 mm
Profile	R01
Load capacity	100 kg
Total height (H)	255 mm
Offset swvl castor (F)	67 mm
Unit weight	3.484 kg
Temperature range from	-25 °C
Temperature range to	50 °C
Tread & tyre hardness	65° Shore A
Bearing type	
Plate size (A,B)	140 x 110 mm
Bolt hole Ø (d)	11 mm
Bolt hole spacing (a,b)	105 x 75-80 mm

Rolling resistance



Operating noise



Floor surface preservation

