

EA986HM-200



EAN: 4047526006105

ID: 6106

Pressed steel swivel castor, medium heavy duty brackets, with top plate fitting, Nylon wheel

Bracket:

Made of heavy pressed steel, with double ball bearing in the swivel head, strong central kingpin, swivel head seals. The special Blickle dynamic riveting process of the swivel head results in minimal swivel head play and smooth rolling characteristics with an increased service life achieved by the work hardening of the ball race grooves. Bolted wheel axle. Zinc-plated, blue-passivated, Cr6-free.

Wheels:

Tyre & running tread: Made of high-quality, impact-resistant nylon. Tread colour: natural white

Rim / wheel centre: -

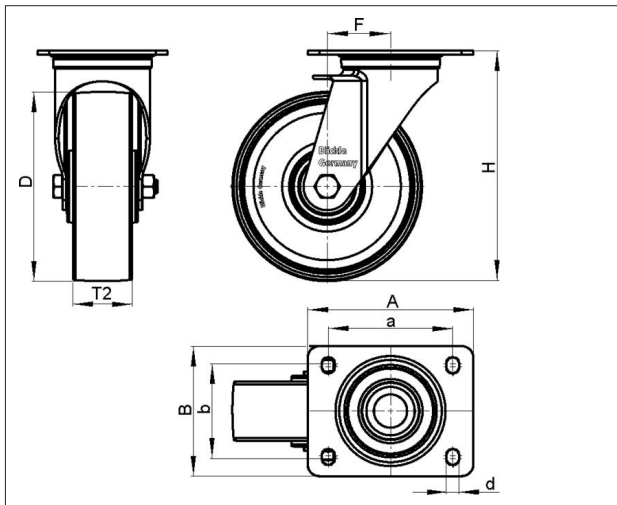

Technical data

Wheel Ø (D)	200 mm
Wheel width (T2)	50 mm
Load capacity	600 kg
Total height (H)	245 mm
Offset swvl castor (F)	65 mm
Unit weight	2.66 kg
Temperature range from	-25 °C
Temperature range to	80 °C
Tread & tyre hardness	70° Shore D
Bearing type	
Plate size (A,B)	140 x 110 mm
Bolt hole Ø (d)	11 mm
Bolt hole spacing (a,b)	105 x 75-80 mm

Rolling resistance



Operating noise



Floor surface preservation



LK-PO 200G

Variants	
	With pressed steel thread guard, zinc-plated
	With 'ideal-stop' brake
	With 'stop-top' brake