

EA986HM-3



EAN: 4047526272951

ID: 272955

, Nylon wheel

Bracket:

Made of heavy pressed steel, swivel bracket with double ball bearing in the swivel head, swivel head seals. The special Blickle dynamic riveting process of the swivel head results in minimal swivel head play and smooth rolling characteristics with an increased service life achieved by the work hardening of the ball race grooves. Bolted wheel axle. Zinc-plated, blue-passivated, Cr6-free.

Wheels:

Tyre & running tread: Made of high-quality, impact-resistant nylon. Tread colour: natural white

Rim / wheel centre: -

Variants:

mit Feststeller "stop-top"

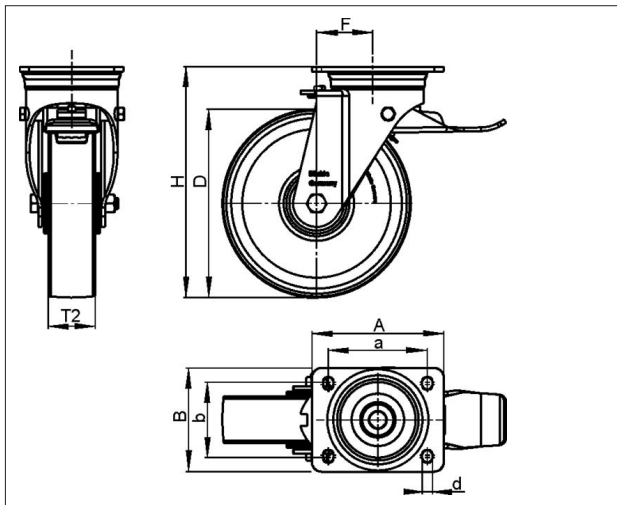

Technical data

Wheel Ø (D)	125 mm
Wheel width (T2)	40 mm
Load capacity	300 kg
Total height (H)	155 mm
Offset swvl castor (F)	48 mm
Unit weight	1.29 kg
Temperature range from	-25 °C
Temperature range to	80 °C
Tread & tyre hardness	70° Shore D
Bearing type	
Plate size (A,B)	100 x 85 mm
Bolt hole Ø (d)	9 mm
Bolt hole spacing (a,b)	80 x 60 mm

Rolling resistance



Operating noise



Floor surface preservation

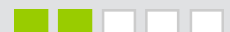

LK-PO 125G-1-ST

Variants	
	With central braking system 'central-stop'
	With pressed steel thread guard, zinc-plated
	With 'stop-top' brake