

EA986HM-75



EAN: 4047526262068

ID: 262063

Pressed steel swivel castor, medium heavy duty brackets, with top plate fitting, Nylon wheel

Bracket:

Made of heavy pressed steel, swivel bracket with double ball bearing in the swivel head, swivel head seals. The special Blickle dynamic riveting process of the swivel head results in minimal swivel head play and smooth rolling characteristics with an increased service life achieved by the work hardening of the ball race grooves. Bolted wheel axle. Zinc-plated, blue-passivated, Cr6-free.

Wheels:

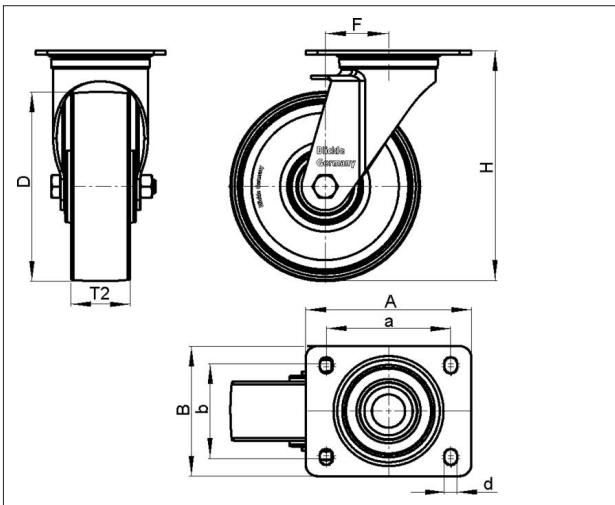

Tyre & running tread: Made of high-quality, impact-resistant nylon. Tread colour: natural white

Rim / wheel centre: -



Technical data

Wheel Ø (D)	75 mm
Wheel width (T2)	32 mm
Load capacity	200 kg
Total height (H)	108 mm
Offset swvl castor (F)	40 mm
Unit weight	0.788 kg
Temperature range from	-25 °C
Temperature range to	80 °C
Tread & tyre hardness	70° Shore D
Bearing type	
Plate size (A,B)	100 x 85 mm
Bolt hole Ø (d)	9 mm
Bolt hole spacing (a,b)	80 x 60 mm

Rolling resistance	
Operating noise	
Floor surface preservation	

LK-PO 75G

Variants



With pressed steel thread guard, zinc-plated



With 'stop-top' brake