

# EA986HP-175



**EAN: 4047526006242**

**ID: 6247**

**Pressed steel swivel castor, heavy duty castors, with top plate fitting, Nylon wheel**

**Bracket:**

Made of heavy pressed steel, with heavy fork and top plate, very strong bolted and secured central kingpin, double ball bearing in the swivel head, additionally reinforced by the integration of four specially shaped and hardened bearing seats resulting in a very high resistance to shock and impact loads. Bolted wheel axle. Bolted wheel axle. Zinc-plated, blue-passivated, Cr6-free.

**Wheels:**

**Tyre & running tread:** Made of high-quality, impact-resistant nylon. Tread colour: natural white

**Rim / wheel centre:** -

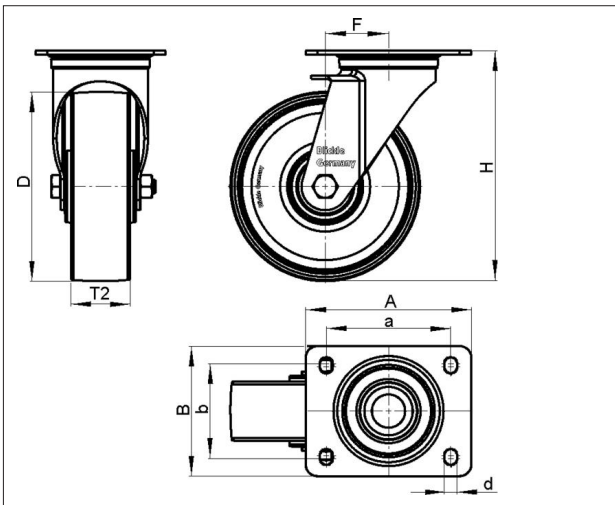

**Technical data**

|                         |                |
|-------------------------|----------------|
| Wheel Ø (D)             | 175 mm         |
| Wheel width (T2)        | 50 mm          |
| Load capacity           | 500 kg         |
| Total height (H)        | 220 mm         |
| Offset swvl castor (F)  | 67 mm          |
| Unit weight             | 3.5 kg         |
| Temperature range from  | -25 °C         |
| Temperature range to    | 80 °C          |
| Tread & tyre hardness   | 70° Shore D    |
| Bearing type            |                |
| Plate size (A,B)        | 140 x 110 mm   |
| Bolt hole Ø (d)         | 11 mm          |
| Bolt hole spacing (a,b) | 105 x 75-80 mm |

Rolling resistance



Operating noise



Floor surface preservation



LH-PO 175K

Variants



With pressed steel  
thread guard, zinc-  
plated