

EA986HP-7



EAN: 4047526011666

ID: 11668

, Nylon wheel

Bracket:

Made of heavy pressed steel, with heavy fork and top plate, very strong bolted and secured central kingpin, double ball bearing in the swivel head, additionally reinforced by the integration of four specially shaped and hardened bearing seats resulting in a very high resistance to shock and impact loads. Bolted wheel axle. Bolted wheel axle. Zinc-plated, blue-passivated, Cr6-free.

Wheels:

Tyre & running tread: Made of high-quality, impact-resistant nylon. Tread colour: natural white

Rim / wheel centre: -

Variants:

mit Feststeller "stop-top"

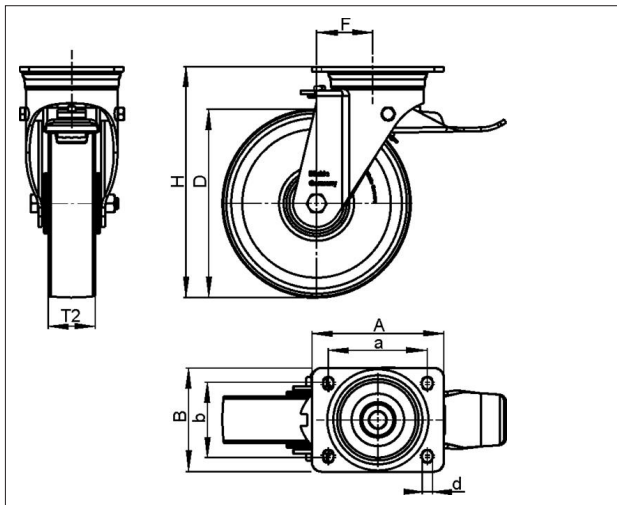

Technical data

Wheel Ø (D)	250 mm
Wheel width (T2)	50 mm
Load capacity	900 kg
Total height (H)	295 mm
Offset swvl castor (F)	82 mm
Unit weight	5.25 kg
Temperature range from	-25 °C
Temperature range to	80 °C
Tread & tyre hardness	70° Shore D
Bearing type	
Plate size (A,B)	140 x 110 mm
Bolt hole Ø (d)	11 mm
Bolt hole spacing (a,b)	105 x 75-80 mm

Rolling resistance



Operating noise



Floor surface preservation



LH-PO 250K-ST

Variants	
	With central braking system 'central-stop'
	With 'ideal-stop' brake
	With 'stop-top' brake