

EA986JK-100



EAN: 4047526579258

ID: 579250

Pressed steel swivel castor, medium heavy duty brackets, with top plate fitting, Heavy duty wheel with Blickle Softhane® polyurethane tread, with aluminium wheel centre

Bracket:

Made of pressed steel, with double ball bearing in the swivel head. The special Blickle dynamic riveting process of the swivel head results in minimal swivel head play and smooth rolling characteristics with an increased service life achieved by the work hardening of the ball race grooves. Bolted wheel axle. Zinc-plated, blue-passivated, Cr6-free.

Wheels:

Tyre & running tread: Made of high-quality, reaction-injected polyurethane-elastomer Blickle Softhane®, very high operational comfort through the especially thick, elastic tread, low-noise operation, low rolling resistance, very good floor preservation, very high abrasion resistance, high cut and tear propagation resistance, very good chemical connection with the wheel centre. Tread colour: green

Rim / wheel centre: Made of die-cast aluminium. Casted tread.

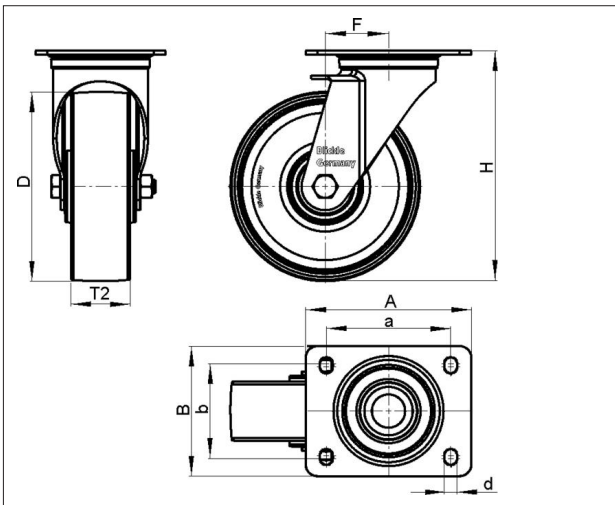

Technical data

Wheel Ø (D)	100 mm
Wheel width (T2)	40 mm
Load capacity	200 kg
Total height (H)	125 mm
Offset swvl castor (F)	36 mm
Unit weight	0.995 kg
Temperature range from	-25 °C
Temperature range to	70 °C
Tread & tyre hardness	75° Shore A
Bearing type	
Plate size (A,B)	100 x 85 mm
Bolt hole Ø (d)	9 mm
Bolt hole spacing (a,b)	80 x 60 mm

Rolling resistance	<input checked="" type="checkbox"/> <input checked="" type="checkbox"/> <input checked="" type="checkbox"/> <input checked="" type="checkbox"/> <input type="checkbox"/>
Operating noise	<input checked="" type="checkbox"/> <input checked="" type="checkbox"/> <input checked="" type="checkbox"/> <input checked="" type="checkbox"/> <input type="checkbox"/>
Floor surface preservation	<input checked="" type="checkbox"/> <input checked="" type="checkbox"/> <input checked="" type="checkbox"/> <input checked="" type="checkbox"/> <input type="checkbox"/>

L-ALST 100K

Variants



With 'stop-top' brake