

EA986KL-250

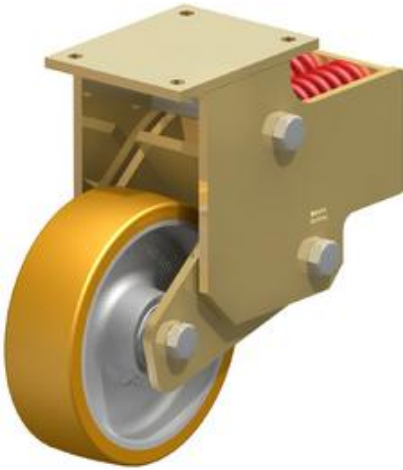

EAN: 4047526285647

ID: 285643

Welded steel heavy duty fixed castor with steel spring, Heavy duty wheel with Blickle Extrathane® polyurethane tread, with cast iron wheel centre

Bracket:

Particularly rugged welded steel construction. Bolted wheel axle. Zinc-plated, yellow-passivated, Cr6-free.

Wheels:

Tyre & running tread: Made of high-quality, reaction-injected polyurethane-elastomer Blickle Extrathane®, low-noise operation, low rolling resistance, good floor preservation, very high abrasion resistance, high cut and tear propagation resistance, very good chemical connection with the wheel centre. Tread colour: light brown

Rim / wheel centre: Made of grey cast iron, with grease nipple, lacquered.

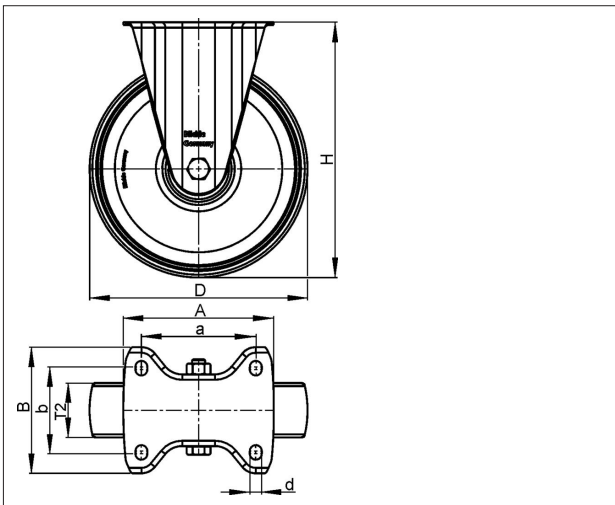

Technical data

Wheel Ø (D)	250 mm
Wheel width (T2)	80 mm
Load capacity	1800 kg
Total height (H)	370 mm
Spring tension	1000 kg
Initial tension	150 kg
Spring travel	45 mm
Unit weight	34.25 kg
Temperature range from	-25 °C
Temperature range to	70 °C
Tread & tyre hardness	92° Shore A
Bearing type	
Plate size (A,B)	200 x 160 mm
Bolt hole Ø (d)	14 mm
Bolt hole spacing (a,b)	160 x 120 mm

Rolling resistance



Operating noise



Floor surface preservation

