

# EA986KW-150



EAN: 4047526048099

ID: 48090

**Welded steel heavy duty swivel castor, Heavy duty nylon wheel**

**Bracket:**

Sturdy welded steel construction, with double ball bearing in the swivel head, additionally reinforced by the integration of four specially shaped and hardened bearing seats, swivel head seal with labyrinth design, fitted grease nipple, bolted and secured with a welded very strong central kingpin. Bolted wheel axle. Zinc-plated, blue-passivated, Cr6-free.

**Wheels:**

**Tyre & running tread:** Made of high-quality, impact-resistant nylon, very rugged, heavy wheel design, very low rolling and swivelling resistance, smooth running performance on even floors, very high abrasion resistance. Tread colour:natural white

**Rim / wheel centre:** -

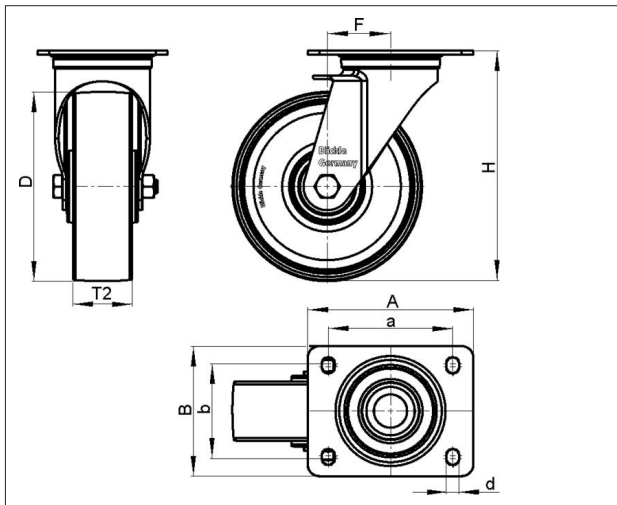

Technical data

Wheel Ø (D)	150 mm
Wheel width (T2)	50 mm
Load capacity	800 kg
Total height (H)	200 mm
Offset swvl castor (F)	55 mm
Unit weight	4 kg
Temperature range from	-25 °C
Temperature range to	80 °C
Tread & tyre hardness	70° Shore D
Bearing type	
Plate size (A,B)	140 x 110 mm
Bolt hole Ø (d)	11 mm
Bolt hole spacing (a,b)	105 x 75-80 mm

Rolling resistance





Operating noise



Floor surface preservation



**LO-SPO 150K**

Variants	
	With directional lock 2 x 180°
	With directional lock 4 x 90°
	With 'stop-top' brake