

EA986KW-200



EAN: 4047526048136

ID: 48132

Welded steel heavy duty swivel castor, Heavy duty nylon wheel

Bracket:

Sturdy welded steel construction, with double ball bearing in the swivel head, additionally reinforced by the integration of four specially shaped and hardened bearing seats, swivel head seal with labyrinth design, fitted grease nipple, bolted and secured with a welded very strong central kingpin. Bolted wheel axle. Zinc-plated, blue-passivated, Cr6-free.

Wheels:

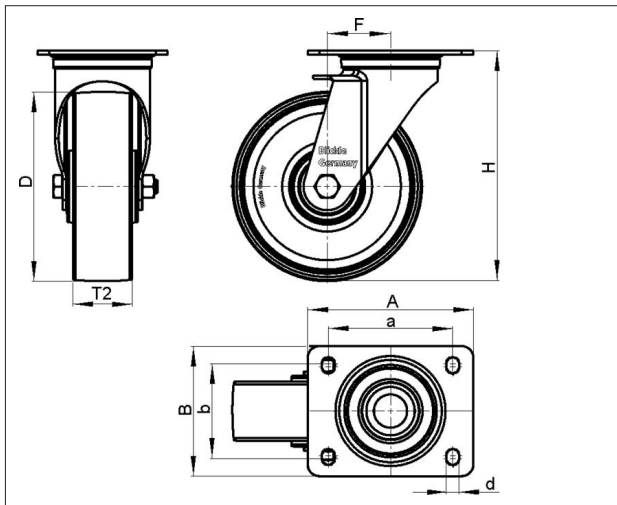

Tyre & running tread: Made of high-quality, impact-resistant nylon, very rugged, heavy wheel design, very low rolling and swivelling resistance, smooth running performance on even floors, very high abrasion resistance. Tread colour:natural white

Rim / wheel centre: -





Technical data

Wheel Ø (D)	200 mm
Wheel width (T2)	50 mm
Load capacity	1250 kg
Total height (H)	245 mm
Offset swvl castor (F)	60 mm
Unit weight	4.769 kg
Temperature range from	-25 °C
Temperature range to	80 °C
Tread & tyre hardness	70° Shore D
Bearing type	
Plate size (A,B)	140 x 110 mm
Bolt hole Ø (d)	11 mm
Bolt hole spacing (a,b)	105 x 75-80 mm

Rolling resistance	
Operating noise	
Floor surface preservation	

LO-SPO 200K

Variants	
	With directional lock 2 x 180°
	With directional lock 4 x 90°
	With 'stop-top' brake