

EA986KZ-125



EAN: 4047526589158

ID: 589150

Heavy duty swivel castor with polyurethane torsion springs, Heavy duty wheel with elastic solid rubber tyres 'Blickle EasyRoll', with aluminium wheel centre

Bracket:

Sturdy steel construction, heavy-duty forged fork, with sealed, lubricated for life grooved ball bearings in the swivel head. Excellent spring damper characteristics due to the patented Woodruff key design. Bolted wheel axle. Zinc-plated, yellow-passivated, Cr6-free.

Wheels:

Tyre & running tread: Made of high-quality elastic solid rubber, in smooth rolling quality "Blickle EasyRoll", very high operational comfort, low-noise operation, low rolling resistance, very good floor preservation, vulcanised on the wheel centre. Tread colour: black

Rim / wheel centre: Made of die-cast aluminium. Vulcanised tyre.

Variants:

mit Fadenschutzaus Stahlblech, verzinkt

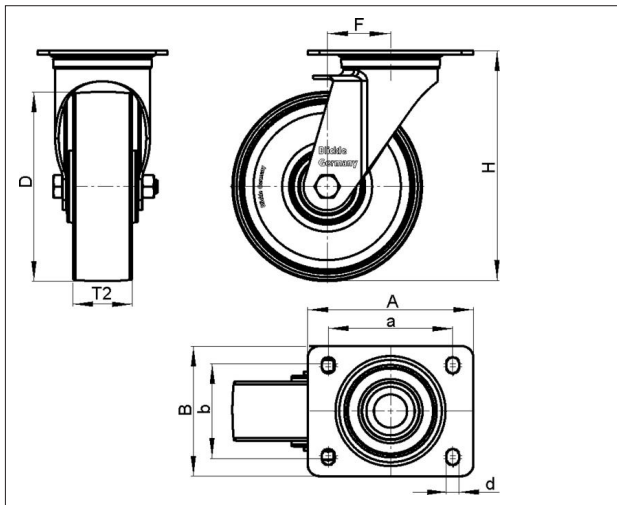

Technical data

Wheel Ø (D)	125 mm
Wheel width (T2)	40 mm
Load capacity	250 kg
Total height (H)	192 mm
Spring tension	290 kg
Initial tension	40 kg
Spring travel	18 mm
Offset swvl castor (F)	45 mm
Unit weight	3.65 kg
Temperature range from	-25 °C
Temperature range to	80 °C
Tread & tyre hardness	65° Shore A
Bearing type	
Plate size (A,B)	100 x 85 mm
Bolt hole Ø (d)	9 mm
Bolt hole spacing (a,b)	80 x 60 mm

Rolling resistance



Operating noise



Floor surface preservation



LPFE-ALEV 125K-FA

Variants



With non-marking grey
tyre