

EA986LC-200



EAN: 4047526025885

ID: 25882

**Stainless steel fixed castor, medium duty brackets, with top plate fitting, Wheel with thermoplastic polyurethane tread, with heavy nylon wheel centre**

**Bracket:**

Made of pressed high-quality, chromium-nickel stainless steel (Material No. 1.4301/AISI 304). All parts incl. axle material are corrosion-resistant. Bolted wheel axle. Vibration-ground finished.

**Wheels:**

**Tyre & running tread:** Made of high-quality thermoplastic polyurethane, high operational comfort, low-noise operation, low rolling and swivelling resistance, good floor preservation, very high abrasion resistance, chemically bonded for an inseparable connection to the wheel centre. Tread colour: dark grey

**Rim / wheel centre:** Made of high-quality, impact-resistant nylon.

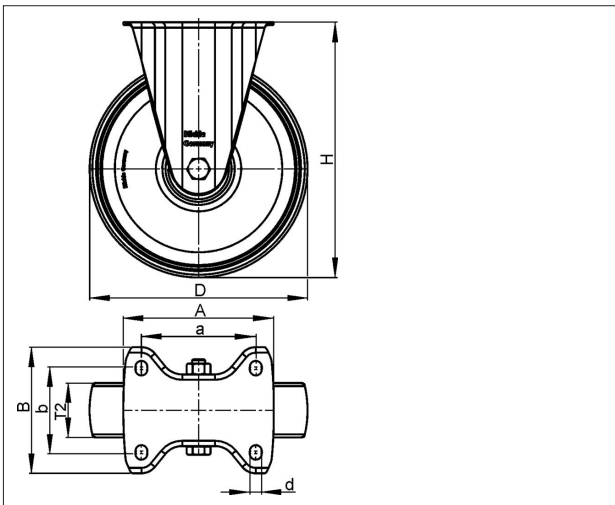

Technical data

Wheel Ø (D)	200 mm
Wheel width (T2)	50 mm
Load capacity	400 kg
Total height (H)	235 mm
Unit weight	1.912 kg
Temperature range from	-25 °C
Temperature range to	70 °C
Tread & tyre hardness	94° Shore A
Bearing type	
Plate size (A,B)	140 x 110 mm
Bolt hole Ø (d)	11 mm
Bolt hole spacing (a,b)	105 x 75-80 mm

Rolling resistance	<input checked="" type="checkbox"/> <input checked="" type="checkbox"/> <input checked="" type="checkbox"/> <input checked="" type="checkbox"/> <input type="checkbox"/>
Operating noise	<input checked="" type="checkbox"/> <input checked="" type="checkbox"/> <input checked="" type="checkbox"/> <input type="checkbox"/> <input type="checkbox"/>
Floor surface preservation	<input checked="" type="checkbox"/> <input checked="" type="checkbox"/> <input checked="" type="checkbox"/> <input type="checkbox"/> <input type="checkbox"/>