

LKX-POTH 125G-1-FI



EAN: 4047526084646

ID: 754894

**Bracket:**

Made of heavy pressed high-quality, chromium-nickel stainless steel (Material No. 1.4301/AISI 304), with double ball bearing in the swivel head, swivel head seals. The special Blickle dynamic riveting process of the swivel head results in minimal swivel head play and smooth rolling characteristics with an increased service life achieved by the work hardening of the ball race grooves. All parts incl. axle material are corrosion-resistant. Bolted wheel axle. Vibration-ground finished.

**Wheels:**

**Tyre & running tread:** Made of high-quality thermoplastic polyurethane, high operational comfort, low-noise operation, low rolling and swivelling resistance, good floor preservation, very high abrasion resistance, chemically bonded for an inseparable connection to the wheel centre.

**Rim / wheel centre:** Made of high-quality, impact-resistant nylon.

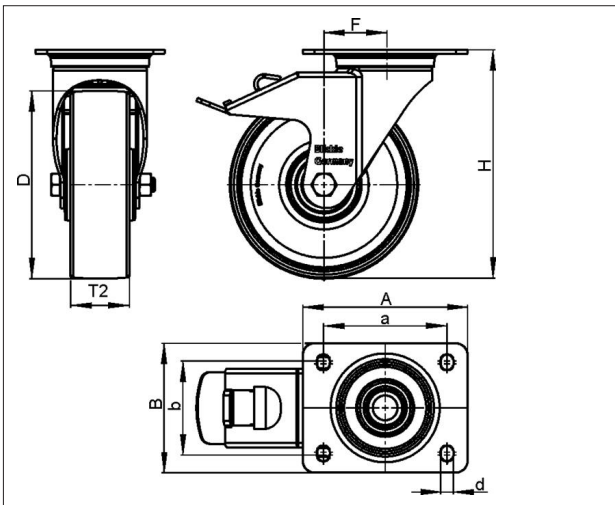

Technical data

Wheel Ø (D)	125 mm
Tread width (T2)	40 mm
Load capacity	250 kg
Overall height (H)	155 mm
Swivel lead (F)	48 mm
Unit weight	1.32 kg
Temperature range from	-25 °C
Temperature range to	70 °C
Tread & tire hardness	94° Shore A
Bearing type	Plain bore
Plate size (A,B)	100 x 85 mm
Bolt hole Ø (d)	9 mm
Bolt hole spacing (a,b)	80 x 60 mm

Rolling resistance



Operating noise



Floor surface preservation

