

LKX-POTH 100G-1



EAN: 4047526084592

ID: 754889

Bracket:

Made of heavy pressed high-quality, chromium-nickel stainless steel (Material No. 1.4301/AISI 304), with double ball bearing in the swivel head, swivel head seals. The special Blickle dynamic riveting process of the swivel head results in minimal swivel head play and smooth rolling characteristics with an increased service life achieved by the work hardening of the ball race grooves. All parts incl. axle material are corrosion-resistant. Bolted wheel axle. Vibration-ground finished.

Wheels:

Tyre & running tread: Made of high-quality thermoplastic polyurethane, high operational comfort, low-noise operation, low rolling and swivelling resistance, good floor preservation, very high abrasion resistance, chemically bonded for an inseparable connection to the wheel centre.

Rim / wheel centre: Made of high-quality, impact-resistant nylon.

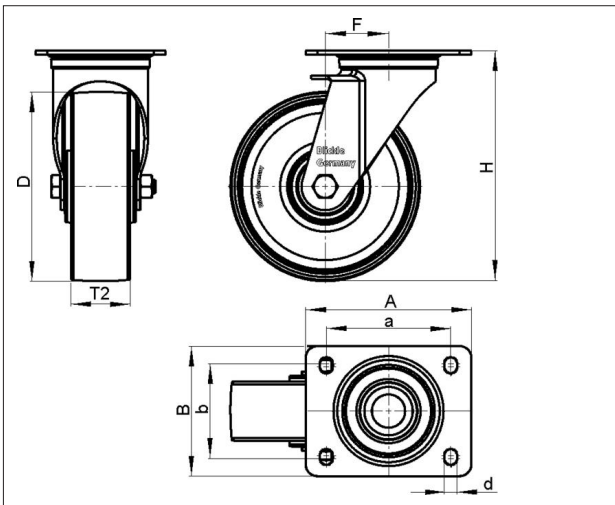

Technical data

| | |
|-------------------------|-------------|
| Wheel Ø (D) | 100 mm |
| Tread width (T2) | 35 mm |
| Load capacity | 300 kg |
| Overall height (H) | 130 mm |
| Swivel lead (F) | 45 mm |
| Unit weight | 0.969 kg |
| Temperature range from | -25 °C |
| Temperature range to | 70 °C |
| Tread & tire hardness | 94° Shore A |
| Bearing type | Plain bore |
| Plate size (A,B) | 100 x 85 mm |
| Bolt hole Ø (d) | 9 mm |
| Bolt hole spacing (a,b) | 80 x 60 mm |

Rolling resistance



Operating noise



Floor surface preservation

