

EA986LL-100



EAN: 4047526285166

ID: 285163

Stainless steel fixed castor with top plate fitting, Nylon wheel

Bracket:

Made of pressed high-quality, chromium-nickel stainless steel (Material No. 1.4301/AISI 304). All parts incl. axle material are corrosion-resistant. Bolted wheel axle. Vibration-ground finished.

Wheels:

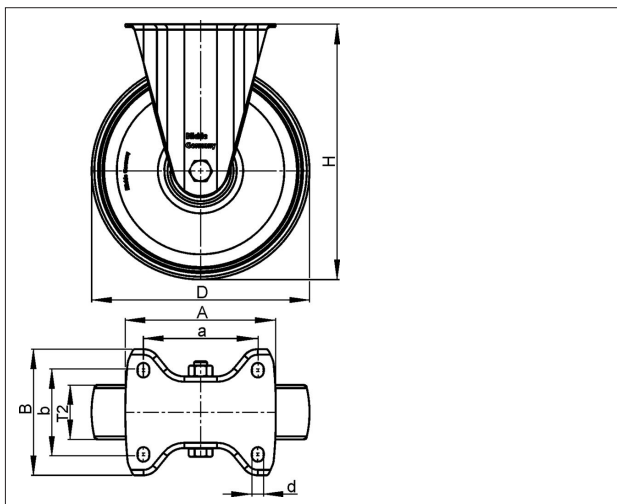

Tyre & running tread: Made of high-quality, impact-resistant nylon. Tread colour:natural white

Rim / wheel centre: -



Technical data

Wheel Ø (D)	100 mm
Wheel width (T2)	37 mm
Load capacity	250 kg
Total height (H)	125 mm
Unit weight	0.528 kg
Temperature range from	-25 °C
Temperature range to	80 °C
Tread & tyre hardness	70° Shore D
Bearing type	
Plate size (A,B)	100 x 85 mm
Bolt hole Ø (d)	9 mm
Bolt hole spacing (a,b)	80 x 60 mm

Rolling resistance	
Operating noise	
Floor surface preservation	