

# B4010A

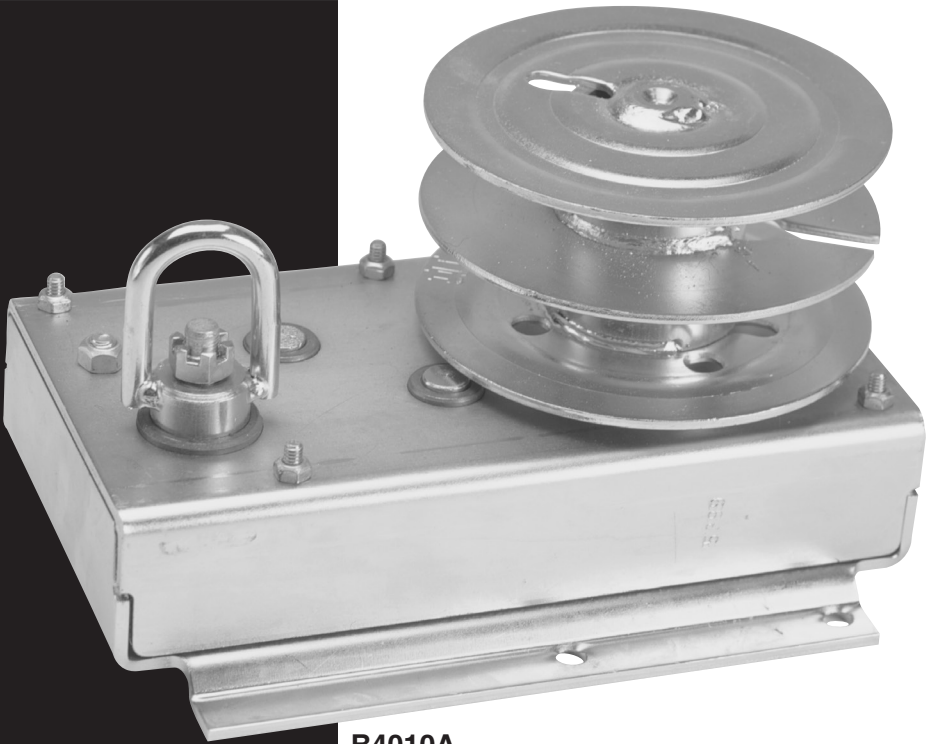

## BRAKE WINCH



B4010A



A Dependable Company Since 1886  
**DUTTON-LAINSON COMPANY**  
Hastings, NE 68902 U.S.A • Tel 402-462-4141 • Fax 402-460-4612  
E-mail [dlsales@dutton-lainson.com](mailto:dlsales@dutton-lainson.com) • Web Site [www.dutton-lainson.com](http://www.dutton-lainson.com)

**ISO 9001** Certified Q.M.S.

**MADE IN  
USA**

 **WARNING** READ INSTRUCTIONS CAREFULLY BEFORE ATTEMPTING TO INSTALL, OPERATE OR SERVICE THIS WINCH. FAILURE TO COMPLY WITH INSTRUCTIONS COULD RESULT IN SERIOUS OR FATAL INJURY. RETAIN THESE INSTRUCTIONS FOR FUTURE REFERENCE.



### IMPORTANT SAFETY INFORMATION

- This brake winch is built for multi-purpose hauling and lifting operations. It is not to be used as a hoist for lifting, supporting or transporting people, or for loads over areas where people could be present.
- Respect this winch. High forces are created when using a winch, creating potential safety hazards. It should be operated and maintained in accordance with instructions. Never allow children or anyone who is not familiar with the operation of the winch to use it. A winch accident could result in personal injury.
- Check winch for proper operation on each use. Do not use if damaged. Seek immediate repairs.
- Never exceed rated capacity. Excess load may cause premature failure and could result in serious personal injury. This winch is designed to operate with two ends of a single cable exiting the drum in opposite directions, each with a load of no more than 2,000 lb/907 kg. Single line or unequal load should not exceed 1,000 lb/454 kg.
- Never apply load on winch with cable fully extended. Keep at least three full turns of cable on the reel.
- This winch is designed to be powered by a 1/2" reversible electric drill using a shepherd's hook connected through the loop drive. If the drill labors significantly, the winch may be overloaded.

**WINCH MOUNTING AND CABLE ATTACHMENT** – For maximum strength and safety, this winch must be mounted with four 3/8" lagscrews or four 3/8" bolts, washers, lockwashers and nuts.

 **WARNING:** The winch must be securely attached to a structural member or frame that is capable of sustaining loads in excess of the winch capacity.

Attach cable by method shown in sketch.

**OPERATING INSTRUCTIONS** – Wind cable on winch reel by turning loop drive in clockwise direction. This should produce a loud, sharp, clicking noise. The load will remain in position when the loop drive is released. Wind cable off the winch reel by turning loop drive counterclockwise (no noise will be produced). The load will remain

in position when the loop drive is released, but for extra security it is recommended that the loop drive be turned clockwise until at least two clicks are heard. This will add extra tightness to the brake mechanism. Always satisfy yourself that the winch is holding the load before releasing the winch loop drive.

**WINCH MAINTENANCE** – In order to insure maximum performance, a periodic inspection for any necessary preventive maintenance should be made. Check at least once annually and more frequently when the winch is exposed to an environment which is particularly dirty or wet.

wear is indicated, disassemble winch and replace worn parts. An occasional drop of oil on the drive shaft bearings and loop drive threads is recommended. **NOTE: Do not oil or grease brake mechanism.**

With load removed, check reel and loop drive for excessive play (sideways movement of 1/8 inch or more would indicate excessive wear). When excessive

Keep winch in good working order. Damaged or severely-worn parts create unnecessary dangers and could result in personal injury or property damage.



NOT FOR THE MOVEMENT OF HUMAN BEINGS

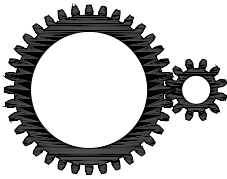

41:1



2000 lb.  
907 kg

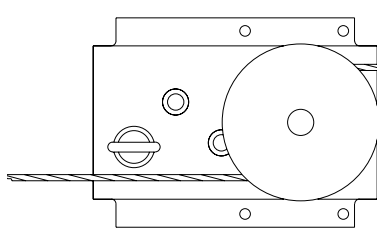

2000 lb.  
907 kg

9/32" x 54'  
(27 per side)  
7mm x 16.5m  
(8.2m/side)

**ENGLISH – DECLARATION OF CONFORMITY** - Dutton-Lainson Company, Hastings, NE 68902-0729 U.S.A. manufactures and declares that the winch identified above fulfills all relevant provisions of the Directive 2006/42/EC. 'G' models also conform to harmonized standards EN 13157 and EN ISO 12100-1 & -2. The technical file may be obtained from the persons listed below.

**DEUTSCH – KONFORMITÄTserklärung** - Dutton-Lainson Company, Hastings, NE 68902-0729, USA, der Hersteller der Winde, erklärt, dass die oben angegebene Winde alle relevanten Bestimmungen der Richtlinie 2006/42/EG erfüllt. Die 'G'-Modelle entsprechen außerdem den harmonisierten Normen EN 13157 und EN ISO 12100-1 und -2. Die technischen Unterlagen sind bei den nachfolgend aufgeführten Personen erhältlich.

**ITALIANO – DICHIARAZIONE DI CONFORMITÀ** - Il fabbricante, Dutton-Lainson Company, Hastings, NE 68902-0729 USA, dichiara che il verrucello di cui sopra è conforme alle disposizioni della direttiva 2006/42/CE e che i modelli 'G' sono inoltre conformi alle norme armonizzate EN 13157 e EN ISO 12100-1 e -2. Il fascicolo tecnico può essere richiesto agli individui indicati qui di seguito.

**PORTUGUÊS – DECLARAÇÃO DE CONFORMIDADE** - A empresa Dutton-Lainson Company, Hastings, NE 68902-0729, nos E.U.A., fabrica o guincho acima identificado e declara que este cumpre todas as provisões relevantes da Diretiva 2006/42/CE. Os modelos "G" cumprem também as normas harmonizadas EN 13157 e EN ISO 12100-1 e -2. Poderá obter o processo técnico junto das pessoas mencionadas abaixo.

**ESPA—OL – DECLARACION DE HOMOLOGACION** - Dutton-Lainson Company, de Hastings, NE 68902-0729 EE.UU., fabrica y declara que el cabrestante arriba identificado satisface todas las provisiones pertinentes de la directriz 2006/42/EC. Los modelos "G" también satisfacen las normas armonizadas EN 13157 y EN ISO 12100-1 y -2. El archivo técnico puede obtenerse de las personas mencionadas a continuación.

**SVENSKA – FÖRSÄKRAN OM ÖVERENSSTÄMMELSE** - Dutton-Lainson Company, Hastings, Nebraska 68902-0729 U.S.A, tillverkar och försäkrar att denna vinsch överensstämmer med alla tillämpliga bestämmelser i Direktiv 2006/42/EC. 'G'-modeller är också förenliga med samordnade normer EN 13157 och EN ISO 12100-1 & -2. Den tekniska filen kan erhållas från de personer, som upptas nedan.

**DANSK – OVERENSSTEMMELSEERKLÆRING** - Dutton-Lainson Company, Hastings, NE 68902-0729 USA fremstiller og erklærer, at skraldespillet identificeret ovenfor er i overensstemmelse med alle relevante krav i direktiv 2006/42/EU. "G" modeller er ligeledes i overensstemmelse med de harmoniserede standarder EN 13157 og EN ISO 12100-1 og -2. Den tekniske fil kan rekvireres gennem de nednævnte personer.

**SUOMI – VAATIMUSTENMUKAISUUSVAKUUTUS** - Dutton-Lainson Company, osoite Hastings, NE 68902-0729 U.S.A, vakuuttaa tämän vintturin valmistajana, että tämä vintturi noudattaa direktiivin 2006/42/EY olennaisia määräyksiä. G-mallit ovat myös harmonisoitujen standardien EN 13157:n ja EN ISO 12100-1 ja EN ISO 12100-2:n mukaisia. Tekniset tiedot on saatavissa alla ilmoitetuilta henkilöiltä.

**NORSK – SAMSVARERKLÆRING** - Dutton-Lainson Company, Hastings, NE 68902-0729 U.S.A. produserer og erklærer at vinsjen angitt ovenfor oppfyller alle relevante krav i direktivet 2006/42/EC. "G"-modellene samsvarer også med de harmoniserte standardene EN 13157 og EN ISO 12100-1 og -2. Den tekniske filen kan skaffes fra personene som er opplistet nedenfor.

**NEDERLANDS – VERKLARING VAN OVERENSTEMMING** - Dutton-Lainson Company, Hastings, NE 68902-0729 VS, fabrikant, verklaart dat de bovengenoemde lier voldoet aan alle betreffende bepalingen van richtlijn 2006/42/EC. 'G' modellen voldoen ook aan de geharmoniseerde normen EN 13157 en EN ISO 12100-1 en -2. Het technische bestand kan bij de hierna vermelde personen worden aangevraagd.

**FRANÇAIS – DÉCLARATION DE CONFORMITÉ** - Dutton-Lainson Company, Hastings, NE 68902-0729 U.S.A. construit le treuil mentionné ci-dessus et déclare qu'il répond à toutes les dispositions applicables de la Directive 2006/42/CE. Les modèles 'G' sont également conformes aux normes harmonisées EN 13157 et EN ISO 12100-1 et -2. Le dossier technique peut être obtenu auprès des personnes indiquées ci-dessous.

**ΕΛΛΗΝΙΚΑ – ΔΗΛΩΣΗ ΣΥΜΜΟΡΦΩΣΗΣ** - Η Dutton-Lainson Company, Hastings, NE 68902-0729 U.S.A. κατασκευάζει και δηλώνει ότι το βαρούλκο που καθορίζεται παραπάνω πληροί όλες τις σχετικές διατάξεις της Οδηγίας 2006/42/ΕΚ. Τα μοντέλα 'G' επίσης συμμορφώνονται με τα αναρμονισμένα πρότυπα EN 13157 και EN ISO 12100-1 & -2. Ο τεχνικός φάκελος είναι διαθέσιμος από τα άτομα τα οποία αναγράφονται παρακάτω.

Hastings, NE USA  
November 2018

Director of Engineering  
Dutton-Lainson Company

Jack Singleton  
Bainbridge International Limited  
Unit 8, Flanders Park, Flanders Road, Hedge End  
Southampton, Hampshire, SO30 2FZ

**ENGLISH**-To obtain a copy of the warranty in English, send a self-addressed envelope to: Dutton-Lainson Company; P.O. Box 729; Hastings NE 68902-0729; U.S.A.

**DEUTSCH**-Wenn Sie eine deutsche Kopie der Garantbestimmungen erhalten möchten, senden Sie bitte einen adressierten Rückumschlag an: Dutton-Lainson Company; P.O.Box 729; Hastings NE 68902-0729; USA

**ITALIANO**-Per ricevere una copia della garanzia in italiano, inviare una busta riportante il proprio indirizzo a: Dutton-Lainson Company, P.O. Box 729, Hastings NE 68902-0729 USA.

**PORTUGUÊS**-Para obter uma cópia da garantia em português, envie um envelope com a sua morada para: Dutton-Lainson; P. O. Box 729; Hastings NE 68902-0729; E.U.A.

**ESPA—OL**-Para obtener una copia de la garantía en español, envíe un sobre con su dirección impresa a: Dutton-Lainson Company, P.O. Box 729; Hastings NE 68902-0729 EE.UU.

**SVENSKA**-För att erhålla ett exemplar av garantin på svenska skicka ett adresserat kuvert till: Dutton-Lainson Company, P.O.Box 729, Hastings NE 68902-0729 U.S.A.

**DANSK**-Man kan få garantibeviset på dansk ved at sende en svarkuvert til: Dutton-Lainson Company, P.O. Box 729, Hastings NE 68902-0729, USA.

**SUOMI**-Takuutodistuksesta saa suomenkielisen kopion lähettämällä riittävästi postimaksulla ja vastaanottajan osoitteella varustetun kirjekuoren osoitteeneseen Dutton-Lainson Company, P.O. Box 729, Hastings NE 68902-0729, U.S.A.

**NORSK**-En kopi av denne garantien på norsk fås ved å sende en konvolutt med eget navn og adresse, til Dutton-Lainson Company, P.O. Box 729, Hastings NE 68902-0729, USA

**NEDERLANDS**-Voor een exemplaar van de garantie in het Nederlands dient u een aan u zelf geadresseerde enveloppe te zenden naar: Dutton-Lainson Company; P.O. Box 729; Hastings NE 68902-0729; U.S.A.

**FRANÇAIS**-Pour obtenir une copie de la garantie en français, envoyez une enveloppe à votre nom et adresse à : Dutton-Lainson Company; P.O. Box 729; Hastings NE 68902-0729; U.S.A.

**ΕΛΛΗΝΙΚΑ**-Για να λάβετε ένα αντίγραφο της εγγύησης στα Ελληνικά, στείλτε ένα φάκελο εσωκλείοντας τα ταχυδρομικά τέλη αποστολής στην εξής διεύθυνση: Dutton-Lainson Company, P.O.Box 729, Hastings NE 68902-0729 U.S.A.



# B4010A

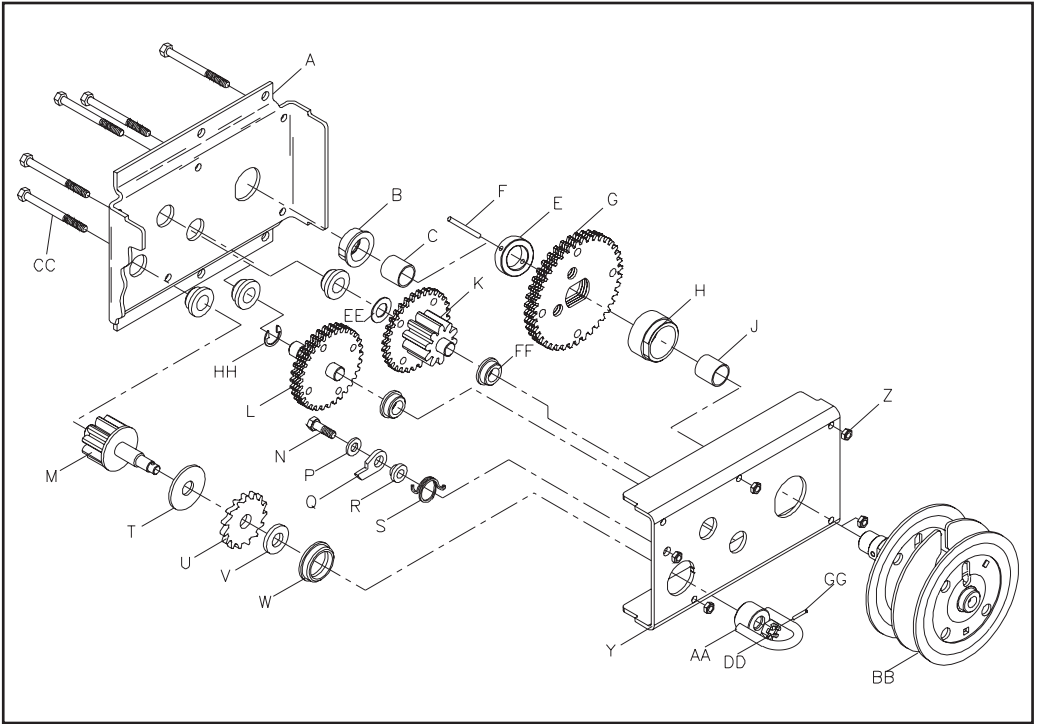

| Ref | Description                  | Part No. |
|-----|------------------------------|----------|
| A   | Base                         | 404934   |
| B   | Reel Bearing Housing 7/8     | 404665   |
| C   | Plastic Sleeve Bearing 7/8   | 206059   |
| E   | Collar                       | 404667   |
| F   | Tension Pin                  | 205021   |
| G   | 40 T Gear Assembly           | 304567   |
| H   | Reel Bearing Housing 1-3/8   | 404664   |
| J   | Plastic Sleeve Bearing 1-3/8 | 206060   |
| K   | Inter. Drive Shaft Assembly  | 304852   |
| L   | Reel Pinion Shaft Assembly   | 304853   |
| M   | Drive Shaft Assembly         | 304851   |
| N   | Ratchet Bolt                 | 205167   |
| P   | Flat Washer                  | 205055   |
| Q   | Ratchet Pawl                 | 404409   |
| R   | Ratchet Spacer               | 404708   |
| S   | Ratchet Spring               | 206104   |

| Ref | Description         | Part No. |
|-----|---------------------|----------|
| T   | Pressure Plate      | 204362   |
| U   | Ratchet Wheel       | 404677   |
| V   | Pressure Washer     | 404163   |
| W   | Shaft Bushing       | 206328   |
| X   | Lock Nut (3/8 - 16) | 204803   |
| Y   | Base Cover          | 404935   |
| Z   | Hex Locknut (5)     | 205014   |
| AA  | Loop Drive Assembly | 304572   |
| BB  | Reel Assembly       | 304565   |
| CC  | Cap Screw (5)       | 205281   |
| DD  | Hex Slotted Nut     | 205032   |
| EE  | Washer 5/8          | 205139   |
| FF  | Shaft Bushing (5)   | 204012   |
| GG  | Cotter Pin          | 206277   |
| HH  | "E" Ring            | 205116   |
|     |                     |          |

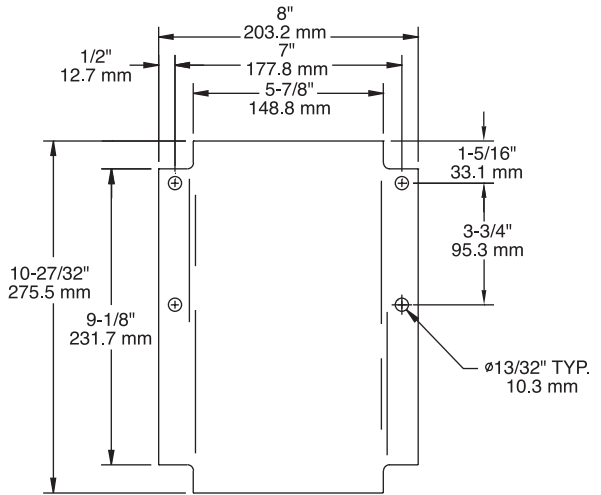
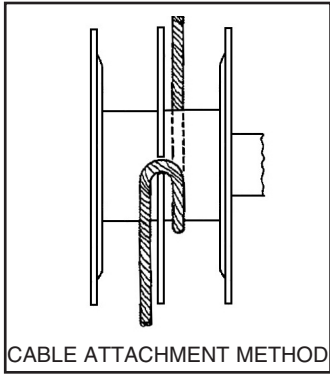

To order replacement parts contact:

**Dutton-Lainson Company**

[www.dlco.com](http://www.dlco.com)

Tel: 800-569-6577

Fax: 402-460-4612

e-mail: [DLsales@dutton-lainson.com](mailto:DLsales@dutton-lainson.com)

**In Europe Contact**

**Bainbridge International Ltd.**

8 Flanders Park

Hedge End

Southampton

Hampshire SO30 2FZ

UK

Tel: +44 (0) 1489-776050

Fax: +44 (0) 1489-776055

[www.bainbridgmarine.co.uk](http://www.bainbridgmarine.co.uk)